

“Unibox E” individual room temperature control and limitation of return temperature in surface heating systems



The Oventrop Quality Management System is certified to DIN-EN-ISO 9001

Technical information

Tender specification:

Oventrop “Unibox E” for surface heating systems
 – for temperature balance of floor or wall surfaces by limiting the return temperature

or

– for individual room temperature control and limitation of return temperature

Max. working temperature: 100°C

Max. working pressure: 10 bar

Max. differential pressure: 1 bar

Depth: 57 mm

Installation set “**Unibox E T**” for individual room temperature control with thermostatic valve (room temperature control) in surface heating systems consisting of:

Wall box unit with presettable thermostatic valve, integrated deaeration, flushing valve and cover plate; with thermostat with ‘0’ setting; valve connection 3/4” for Oventrop compression fittings.

Temperature range: 7-28°C (room temperature)

0 = Complete shut off

* = about 7°C, frost protection symbol

1 = about 12°C

2 = about 16°C

3 = about 20°C

4 = about 24°C

5 = about 28°C

The minor graduations between the figures 2-4 represent a change of the room temperature of about 1°C.

Item nos.: see table

Installation set “**Unibox E RTL**” for temperature limitation of heating surfaces with return temperature limiter consisting of:

Wall box unit with integrated return temperature limiter, integrated deaeration, flushing valve and cover plate; valve connection 3/4” for Oventrop compression fittings.

Temperature range: 20-40°C (return temperature)

Graduation 0 – 40; the figures indicate the max. return temperatures in °C.

Item nos.: see table

Installation set “**Unibox E plus**” for individual room temperature control with thermostatic valve and for temperature limitation of heating surfaces with return temperature limiter consisting of:

Wall box unit with presettable thermostatic valve, integrated return temperature limiter, integrated deaeration, flushing valve and cover plate; with thermostat with ‘0’ setting; valve connection 3/4” for Oventrop compression fittings.

Temperature range: 7-28 °C (room temperature)

20-40°C (return temperature)

Item nos.: see table

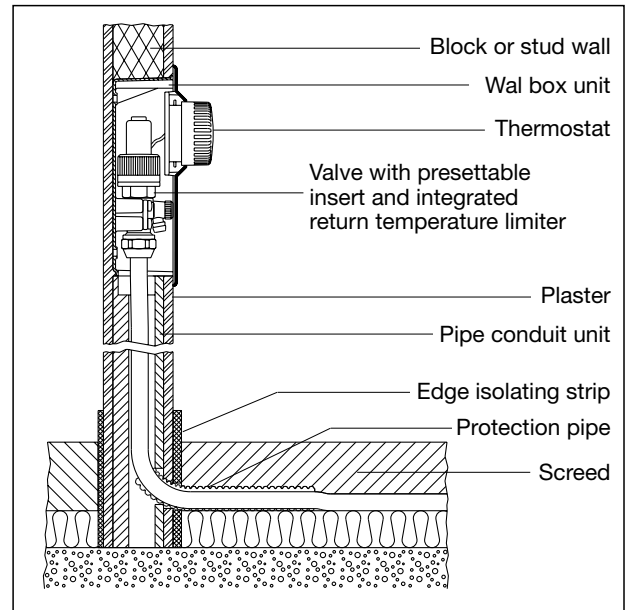

“Unibox E plus”, depth 57 mm

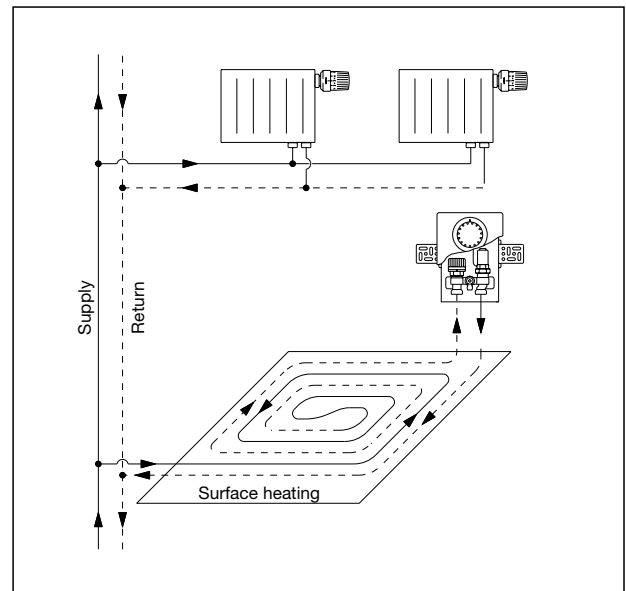

Installation sketch individual room temperature control and limitation of return temperature

	Item no.	Thermostat	Return temperature limiter	Cover		Visible thermostat	
				white	chrome plated	white	chrome plated
“Unibox E T”	102 26 32	X		X		X	
	102 26 42	X			X		X
“Unibox E RTL”	102 26 31		X	X			
	102 26 41		X		X		
“Unibox E plus”	102 26 33	X	X	X		X	
	102 26 43	X	X		X		X
“Unibox E vario”	102 26 34		X	X			
	102 26 44		X		X		

Installation set **“Unibox E vario”** as basic model for temperature limitation of heating surfaces with return temperature limiter consisting of:

Wall box unit with presettable thermostatic valve, integrated return temperature limiter, integrated deaeration, flushing valve and closed cover plate; valve connection 3/4” for Oventrop compression fittings.

Temperature range: 20-40°C (return temperature)

Item nos.: see table

For room temperature control, the following items have to be ordered separately:

- Thermostat with remote control “Uni LH” (see catalogue “Products”, page 13.23)

or

- Room thermostat and actuator (see catalogue “Products”, pages 1.12, 1.13)

Pipe conduit unit, depth 100 cm, completely insulated, includes fixing material:

Item no. 102 26 50

Compression fittings (see catalogue “Products”, page 1.45)

Application:

The different models of the “Unibox” are suitable for the operation of surface heating in a room with a heating surface up to 20 m². They are designed for the connection of one heating circuit. Two circuits are required for larger heating surfaces. In this case, the pipes must be of the same length and have to be connected with the help of a T-piece or the “h” fitting, item no. 102 87 50 and the connection fitting, item no. 101 63 04 (see installation sketch on page 4) before entering the “Unibox”. The pressure loss can be reduced with the help of a larger sized return pipe. When installing heating pipes with an inner diameter of 12 mm, a pipe length of 100 m per heating circuit should not be exceeded. When laying the pipe, it is to be observed that the supply and the return pipe are alternately laid side by side. See e.g. spiral laying in the installation sketches. The examples of calculation mentioned below show some examples of laying.

The **“Unibox E RTL”** allows the temperature limitation of heating surfaces. The room temperature is controlled via the radiators. Installation is carried out in combination with a radiator heating with a max. flow temperature of 70°C.

The **“Unibox E T”** allows the control of the room temperature via the surface heating. It is used in combination with a low temperature heating installation with a max. flow temperature of 55°C.

The **“Unibox E plus”** allows the individual room temperature control with a thermostatic valve and the temperature limitation of the heating surfaces with a return temperature limiter. As for the “Unibox E RTL”, installation is carried out in combination with a radiator heating with a max. flow temperature of 70°C.

The **“Unibox E vario”** is used like a “Unibox E plus” when mounting a thermostat with remote control or a room thermostat and an actuator, and without these additions like a “Unibox E RTL”.

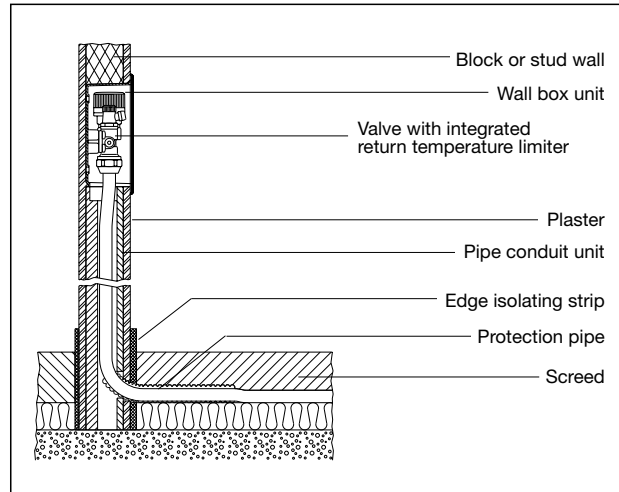

“Unibox E RTL”, depth 57 mm

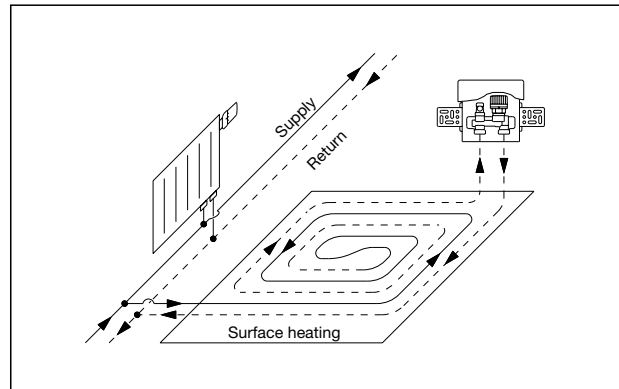

Installation sketch limitation of return temperature

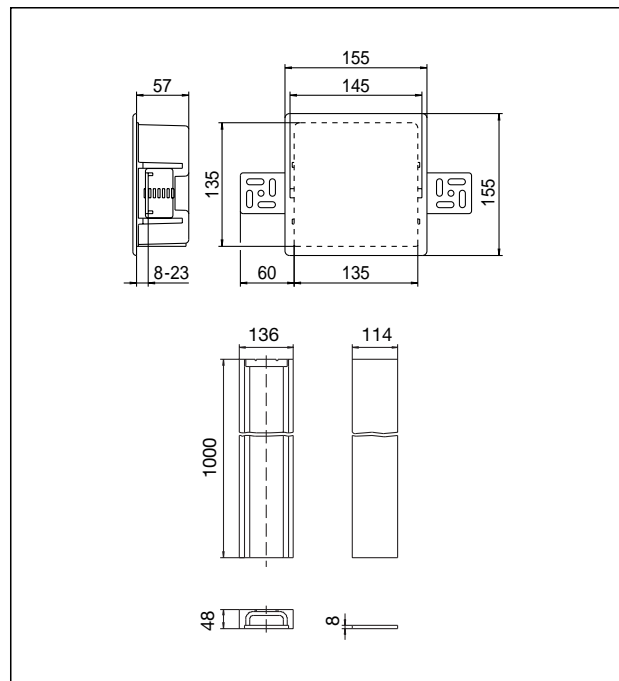

Dimensions “Unibox E RTL” and pipe conduit unit

Function:

The “Unibox E RTL” serves to limit the return temperature of surface heating. The “Unibox E RTL” should be installed in such a position that the heating medium passes through the heating circuit first and then through the valve. On its way from the entry into the heating surface to the return temperature limiter, the heating medium cools down.

The flow is automatically controlled by a sensor element being in touch with the heating fluid. The return temperature is set at the handwheel. The guidelines regarding heating up and initial operation are to be observed.

The temperature of the surface heating can be corrected by turning the handwheel.

Normally, the “Unibox E RTL” is operated in a room with an additional radiator. The surface heating covers the basic heat demand whereas the radiator takes on the control of the room temperature.

The “Unibox E T” may only be operated with a max. flow temperature of the surface heating of 55°C (low temperature heating). It offers a full individual room temperature control via the surface heating. It is recommended to install the “Unibox E T” in such a position that the heating medium passes through the heating circuit first and then through the valve. This way, the automatic thermostat controls the desired room temperature exactly. The hydronic balancing is carried out at the presettable valve insert.

The “Unibox E T” can be operated without an additional radiator provided that the heat output capacity of the surface heating is sufficient.

The “Unibox E plus” serves to control the temperature of individual rooms via the surface heating and to limit the temperature of the heating surface with the help of the return temperature limiter at the same time.

The “Unibox E plus” is installed in the same position as the “Unibox E RTL”. The heating medium has to pass through the heating circuit of the surface heating first and then through the valve. On its way from the entry into the heating surface to the return temperature limiter, the heating medium cools down.

The flow is automatically controlled by a sensor element being in touch with the heating fluid.

The return temperature is set at the handwheel. The notes below regarding heating up and initial operation are to be observed.

The surface temperature can be corrected by turning the handwheel.

The automatic thermostat controls the desired room temperature. The hydronic balancing is carried out at the presettable valve insert. The “Unibox E plus” can be operated without an additional radiator, provided the heat output capacity of the surface heating is sufficient.

The “Unibox E vario” offers the same function as the “Unibox E plus” when mounting a thermostat with remote control or a room thermostat and an actuator. The return temperature is limited with the help of the integrated return temperature limiter.

For use as a “Unibox E vario”, return temperature control has to be added. This can be done by choosing one of the following options (to be ordered separately):

1. With room thermostat and electrothermal actuator
The electrothermal actuator is mounted on the vertical connection inside the “Unibox E vario”.

To lead the connecting cable towards the room thermostat, drill a hole (Ø about 8 mm) at the marked point (sticker) on the outer wall of the wall unit.

Electrical connections, especially in humid locations, must be carried out in accordance with the local Electricity Regulations and Standards.

Temperature range: 5-30°C (room temperature)
20-40°C (return temperature)

2. With thermostat with remote control “Uni LH”
The control is mounted on the vertical valve connection inside the “Unibox E vario”.

The capillary towards the room temperature sensor can be led downwards out of the “Unibox E vario”. Laying through an empty pipe is advantageous.

Temperature range: 7-28°C (room temperature)
20-40°C (return temperature)

Without these additions, control corresponds to the “Unibox E RTL”. Hydronic balance can additionally be carried out with the help of the presettable valve insert.

Temperature range: 20-40°C (return temperature)

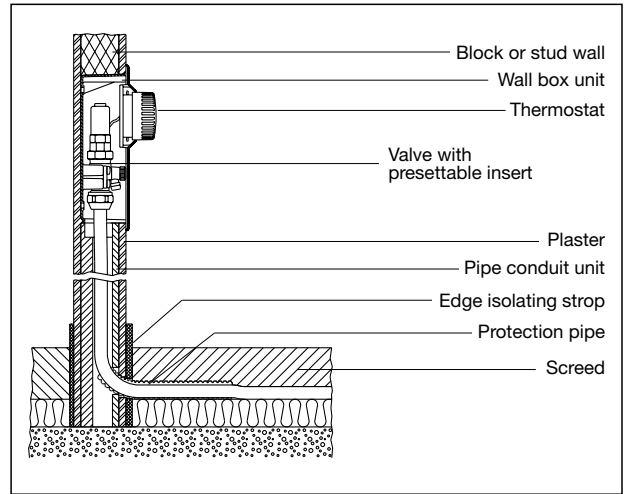

“Unibox E T”, depth 57 mm

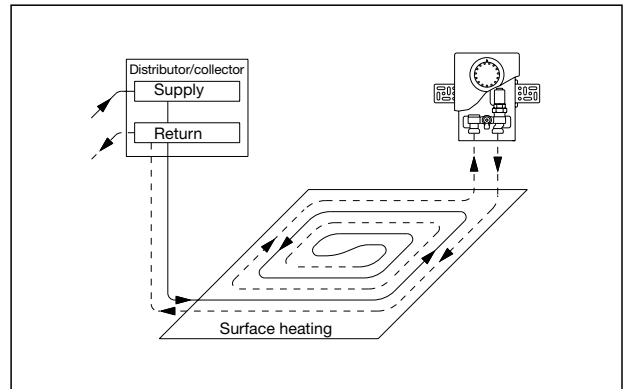

Installation sketch individual room temperature control

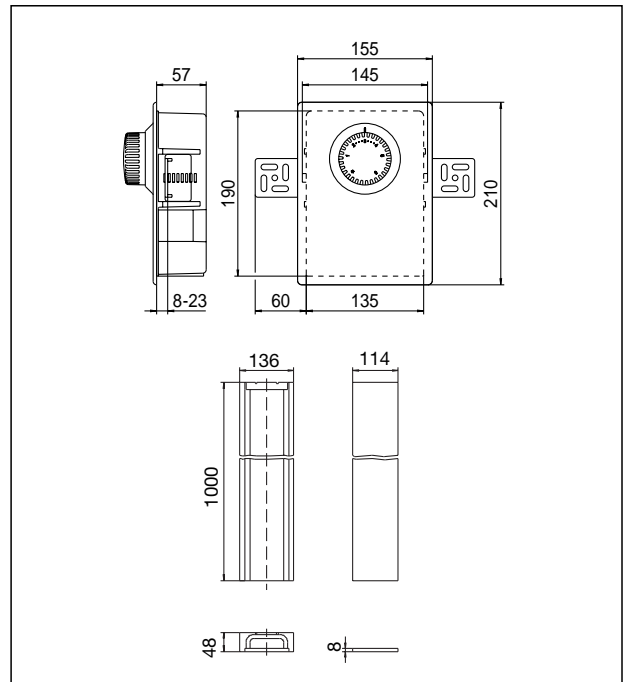

Dimensions “Unibox E T”, “Unibox E plus”, “Unibox E vario” and pipe conduit unit

Installation and assembly:

If the surface heating is installed as an underfloor heating, the lower edge of the "Unibox E" should be at least 20 cm above the finished floor, the front edge should be on a level with the finished wall. The thickness of plaster and tiles has to be observed. A comfortable operation is given if it is installed at the height of light switches.

The thermostat should not be influenced by other heat sources.

- Do not install near other heat sources, e.g. additional radiators.
- Avoid direct sunlight to the thermostat.
- Do not install at a location exposed to draught.

The wall box unit is to be installed with the hole pointing downwards. Alignment and fixing are made by use of the enclosed elbows. They can be fixed at the side of the wall box unit in different positions.

The wall box unit is sealed in the wall. The valve is protected by a cover made of corrugated cardboard.

For a simple installation of the vertical pipework, place the pipe conduit unit, item no. 102 26 50, into the wall below the wall box unit, shorten if required. Later, the front of the pipe conduit unit will be under plaster.

If required, lay an empty pipe for the cable between room thermostat and actuator or respectively the capillary of the thermostat with remote control.

If the "Unibox E vario" is equipped with an electric room thermostat and an actuator in bathrooms, electrical connections must be carried out in accordance with the local Electricity Regulations and Standards.

When designing the floor as a surface heating, the construction e.g. regarding thermal and sound insulation, has to comply with the valid rules, standards and regulations.

When installing the pipework, the correct sequence has to be observed to ensure a perfect function of the "Unibox E":

- Provide derivation from the supply pipe of the two pipe heating system.
- Laying of the heating circuit. When installing a "Unibox E" with limitation of return temperature, the pipes have to be laid spiral patterned (see installation sketch). A constant temperature distribution is achieved.
- Connection of the pipework to the "Unibox E", marked direction of flow has to be observed. **Valve always behind the heating circuit.** Remove the protection cover of the "Unibox" as well as the front cover of the pipe conduit unit.
- Installation of the connecting pipe to the return pipe of the two pipe heating system.

The surface heating can be installed with any standard pipe material.

The Oventrop programme includes suitable compression fittings. The corresponding installation instructions are to be observed. **Insert the copper pipe a maximum of 5 mm deeper than the fitting.** An open ring spanner 30 mm, e.g. Oventrop item no. 140 10 91, is recommended to tighten the fittings.

The installation is filled and bled, e.g. at the valve. Then carry out leakage test and remount protection cap of the valve and front cover of the pipe conduit unit.

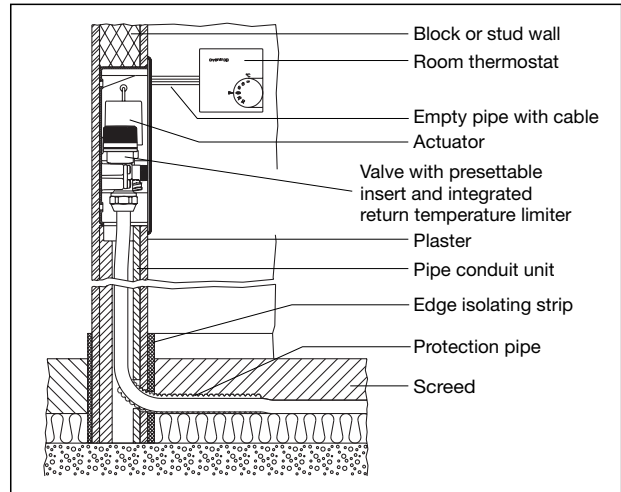

"Unibox E vario" with room thermostat and actuator

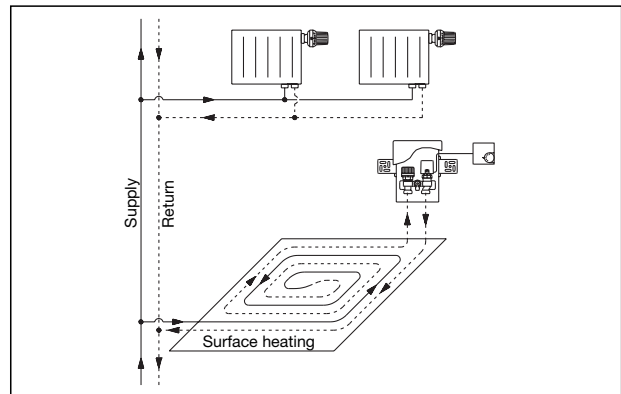

Installation sketch "Unibox E vario" with room thermostat and actuator

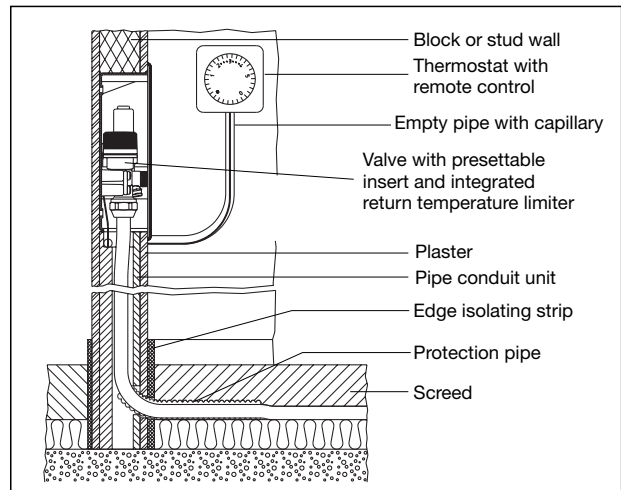

"Unibox E vario" with thermostat with remote control "Uni LH"

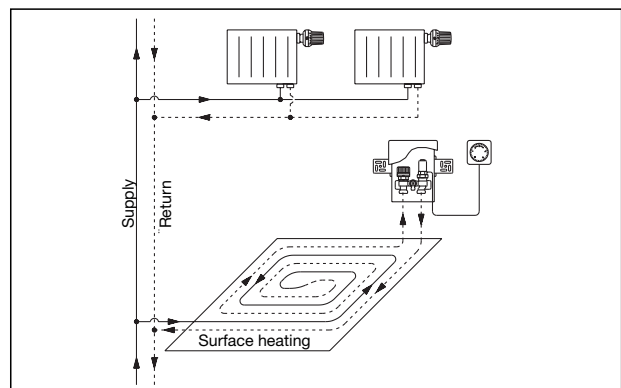

Installation sketch "Unibox E vario" with thermostat with remote control "Uni LH"

Important note for heating up:

After all plastering is finished, a heating screed complying with standards has to be laid. The concrete and anhydrite screed have to be heated up according to EN 1264-4 or ZVSHK documentations FBH-D1 to D4.

Start heating up:

- at the earliest 21 days after having laid the concrete floor
- at the earliest 7 days after having laid the anhydrite concrete floor

Heat up slowly!

3 days with a flow temperature of about 25°C and then

4 days with a flow temperature of about 55°C

Flow temperature is only controlled by the boiler control.

Open valve of the “Unibox E”: Turn the handwheel of the return temperature limiter to the maximum position and/or open presettable valve insert by turning the protection cap about 1 turn.

Instructions of the concrete manufacturers are to be observed.

After having completed all building work, the protection cover is removed.

For the “Unibox E T” and the “Unibox E plus”, mount the remote control on the right hand valve insert, lead the capillary downwards and fit the enclosed valve insulation inside the box. The capillary may not be kinked or damaged.

For the “Unibox E vario”, mount the thermostat “Uni LH” with remote control or an actuator on the right hand valve insert.

Mount and adjust the white or chrome plated cover (front cover).

Important note for putting the system into operation:

The recommended temperature range of the return temperature limiter is between 25°C and 40°C.

The maximum permissible concrete temperature near the heating pipes may not be exceeded:

- 55°C for concrete and anhydrite concrete
- 45°C for mastic asphalt concrete
- or according to the instructions of the concrete manufacturer

Examples of calculation:

“Unibox E RTL” or “Unibox E plus”

Application: Bathroom
 Pipe material: Composition pipe “Copipe” 16 x 2 mm
 Room temperature: 24°C
 Room temperature of the room below: 20°C
 Max. heating surface temperature: 33°C
 $R_{s1} = 0.02 \text{ m}^2\text{K/W}$ (tiles)
 Set return temperature: 35°C

Laying distance [mm]	Pipe length [m]	Heating surface [m ²]	Spec. heat output [W/m ²]	Pressure loss pipework [mbar]	Flow rate [l/s]
75	100	7,5	93	55	0.0197
150	80	12	76	75	0.0261
150	100	15	76	137	0.0325
225	80	18	63	110	0.0322
225	89	20	60	115	0.0314
300	67	20	51	81	0.0300

“Unibox E T”

Application: Living area
 Pipe material: Composition pipe “Copipe” 16 x 2 mm
 Room temperature: 20°C
 Room temperature of the room below: 20°C
 Max. heating surface temperature: 29°C
 $R_{s1} = 0.1 \text{ m}^2\text{K/W}$ (parquet)
 Flow temperature: 50°C

Laying distance [mm]	Pipe length [m]	Heating surface [m ²]	Spec. heat output [W/m ²]	Pressure loss pipework [mbar]	Flow rate [l/s]
75	100	7,5	100	83	0.0247
150	80	12	85	113	0.0328
150	100	15	80	118	0.0300
225	80	18	70	114	0.0331
225	89	20	67	108	0.0303
300	67	20	61	104	0.0342

For the design of the installation it has to be observed that the pressure loss of the pipe and the valve may not exceed a sum of 300 mbar.

The models

- “Unibox E plus”
- “Unibox E T”
- “Unibox E RTL” (if temperature limitation of a heating surface and the thermostatically controlled radiator are located in the same room)

comply with the Decree for Energy Saving valid since February 2002 (EnEV § 12).

Advantages:

- simple installation
- best possible control characteristics
- stylish unit (flat model)
- comfortable height for use of control
- smart optical integration into the wall
- cover plate in modern colours white RAL 9010 and chrome plated
- rotating plastic cover plate which can be fitted without screws
- the strong pipe conduit unit also serves as insulation
- suitable for the connection to any standard pipes for surface heating systems
- no auxiliary energy (current) required
- economical installation of a surface heating
- higher living comfort
- optimum control even of combined installations (surface heating/radiator connection)
- integrated deaeration

Performance data “Unibox E T” and “Unibox E plus”

Presetting	1	2	3	4	5	6
k_V value at 1K P-deviation	0.043	0.11	0.19	0.24	0.26	0.28
k_V value at 1,5K P-deviation	0.043	0.11	0.23	0.33	0.39	0.42
k_V value at 2K P-deviation	0.043	0.12	0.25	0.37	0.47	0.52
k_{vs}						0.75

Subject to technical modification without notice.

Product range 13
 ti 152-1/20/MW
 Edition 2006

Pressure loss chart for “Unibox E RTL”

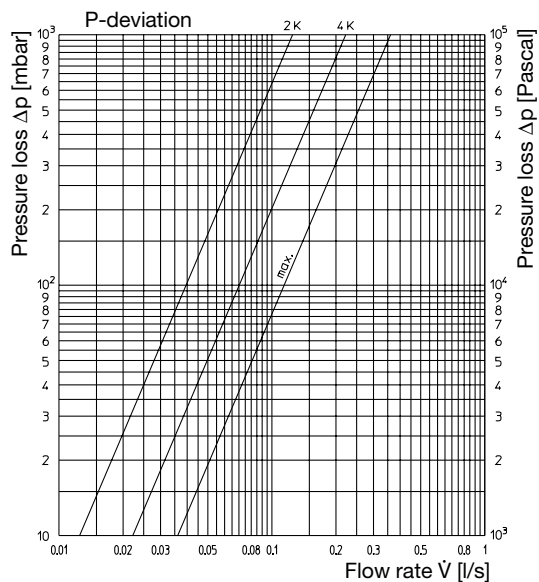

Pressure loss chart “Unibox E T” at 2 K P-deviation and “Unibox E plus”, RTL completely opened

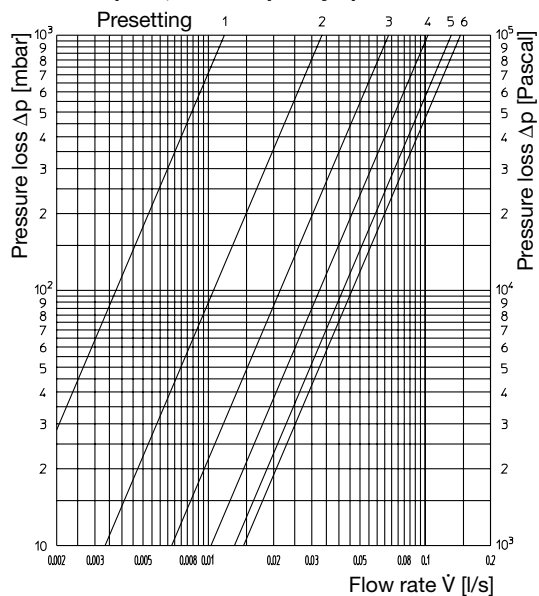

at 1 K P-deviation

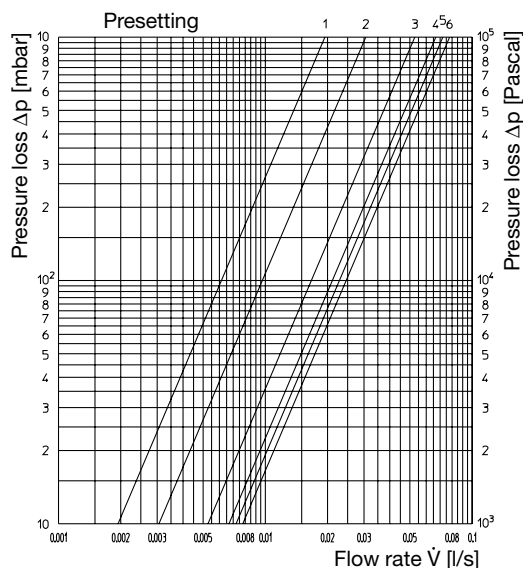

OVENTROP UK LTD.
 Unit 1 – The Loddon Centre
 Wade Road
 Basingstoke, Hampshire RG24 8FL
 Great Britain
 Telephone (01256) 330441
 Telefax (Sales) (01256) 330525
 Telefax (General) (01256) 470970
 E-Mail sales@oventrop.co.uk

F. W. OVENTROP GmbH & Co. KG
 Paul-Oventrop-Straße 1
 D-59939 Olsberg
 Germany
 Telephone (02962) 82-0
 Telefax (02962) 82-450
 E-Mail mail@oventrop.de
 Internet www.oventrop.de