



### Cast iron double regulating/ commissioning valves PN 16 "Hydrocontrol G"

Technical information

#### Application:

Oventrop double regulating and commissioning valves "Hydrocontrol G" are installed in the pipework of hot water central heating and cooling systems and serve to achieve a hydronic balance between the various circuits of the system. The double regulating and commissioning valves may be installed in either the supply or the return pipe.

When installing the valves, it is to be observed that the direction of flow conforms with the arrow on the valve body and the valve is installed with a minimum of 3 D (3 x nominal pipe diameter) of straight pipe at the valve inlet and of 2 D (2 x nominal pipe diameter) of straight pipe at the valve outlet.

#### Advantages:

- the location of the functioning components on one side allows a simple assembly and easy operation
- only one valve for 5 functions:
  - presetting
  - measuring
  - isolating
  - filling
  - draining
- low pressure loss (oblique pattern)
- infinitely adjustable presetting which can be read off in any position of the valve, exact measurement of pressure loss and flow by use of pressure test points
- fill and drain ball valve with internal stop and pressure test point with O-ring seal between valve body and test point (no additional seal required)
- patented measuring channel led around the stem assembly to the test points ensures the best possible accuracy between the differential pressure measured at the pressure test point and the actual differential pressure of the valve

#### Function:

The balance is achieved by a presetting with memory position. The calculated flow rate or pressure loss for each individual pipe can be preset centrally and be regulated precisely. The required values of presetting can be obtained from the flow charts. All intermediate values are infinitely adjustable. The selected presetting can be read off two scales (basic setting longitudinal scale and fine setting peripheral scale, see illustration presetting). The presetting is reproducible by opening the valve until stop. The flow charts are valid for the installation of the double regulating and commissioning valves in the supply or the return pipe, provided that the direction of flow conforms with the arrow on the valve body. The Oventrop double regulating and commissioning valves have two threaded ports which are equipped with the pressure test points for measuring the differential pressure.

#### Accessories sets 2 1/2"- 12":

Set no. 1 = 1 fill and drain ball valve	106 01 91
Measuring adapter	102 02 98
Extension for accessories sets (3.15")	106 02 95
Extension for accessories sets (1.57")	168 82 95
Stem extension (2 1/2"-6", 1.38")	168 82 97

#### Connection:

- Groove connections for couplings  
 Suitable for couplings of the following systems:
- Victaulic
  - Grinell



Double regulating and commissioning valves 2 1/2" - 6"



Double regulating and commissioning valves 8" - 12"

**Double regulating and commissioning valve  
DN 2 1/2" – 6"  
Measuring technic "classic"**

**Tender specification:**

Overtrop double regulating and commissioning valves with secured, infinitely adjustable presetting controllable at any time by use of the flow limiting device.

Sizes 2 1/2" - 6"

Size	Item no.
2 1/2"	106 30 51
3"	106 30 52
4"	106 30 53
5"	106 30 54
6"	106 30 55

Lengths according to DIN EN 558-1 (basic series 1)

Valve body made of cast iron (EN-GJL-250 DIN EN 1561), bronze bonnet and disc, stem made of brass resistant to dezincification. Disc with PTFE seal. Maintenance-free stem seal due to double EPDM O-ring. Groove connections for couplings.

All functioning components on one level. Pressure test point and fill and drain ball valve interchangeable.

**Presetting 2 1/2" - 6":**

- The value of presetting of the valve is adjusted by turning the handwheel.
  - The display of the basic setting is shown by the longitudinal scale together with the sliding indicator. Each turn of the handwheel is represented by a line on the longitudinal scale.
  - The display of the fine setting is shown by the peripheral scale on the handwheel together with the marking. The subdivisions of the peripheral scale correspond to 1/10th of a turn of the handwheel.
- Remove cover plug by introducing a screwdriver in the slot and gently prising it off.
- Undo screw by use of a 8 mm Allen key.
- With the valve at the required value of presetting, turn the inner adjustment stem clockwise until it seats. This can be done by using the long end of a 4 mm Allen key.
- Replace and tighten screw by use of a 8 mm Allen key.
- Refit cover plug.

**Visibility/readability of the setting scales:**

Depending on the installation position of the double regulating and commissioning valve, an improvement of the visibility/readability of the setting scales is obtained by twisting the scales. With the valve fully closed and the two setting scales on "0", remove cover plug, undo screw and with a light tug pull the handwheel from the valve stem. Next, without altering the presetting (still indicating "0"), adjust the position of the handwheel so that the indicator window of the longitudinal scale is clearly visible. Finally refit the handwheel to the valve stem, tighten the screw and replace the cover plug.

**Protecting the setting:**

A sealing wire may be fitted through the hole in the handwheel and a lead seal be fitted.

**Locking the handwheel:**

The handwheel can be locked in any position (display 1/10th of a turn). Fit the enclosed clip in the cut-out in the handwheel below the holes between the guides, making sure it locates into the sliding indicator (see sketch). The clip can now be sealed as illustrated. It is essential that the sealing wire is fitted tightly.

**Dimensions:**

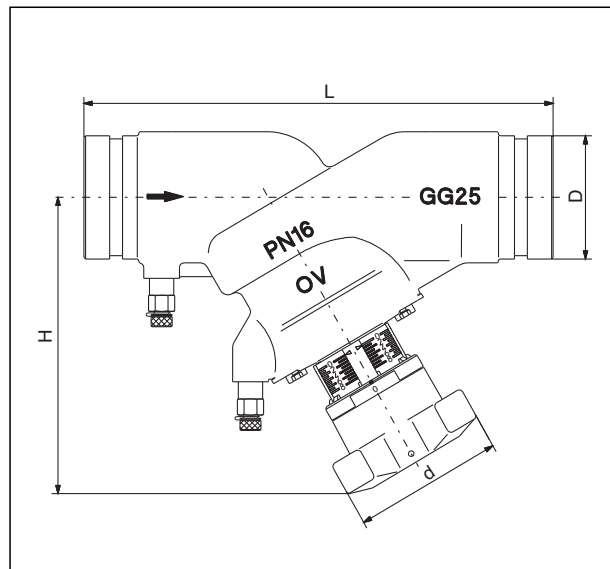

Size	L	D	H	d	Item no.
2 1/2"	11.42	2.87	7.4	4.33	106 30 51
3"	12.2	3.5	7.99	4.33	106 30 52
4"	13.78	4.5	9.45	6.3	106 30 53
5"	15.75	5.563	11.14	6.3	106 30 54
6"	18.9	6.63	11.22	6.3	106 30 55

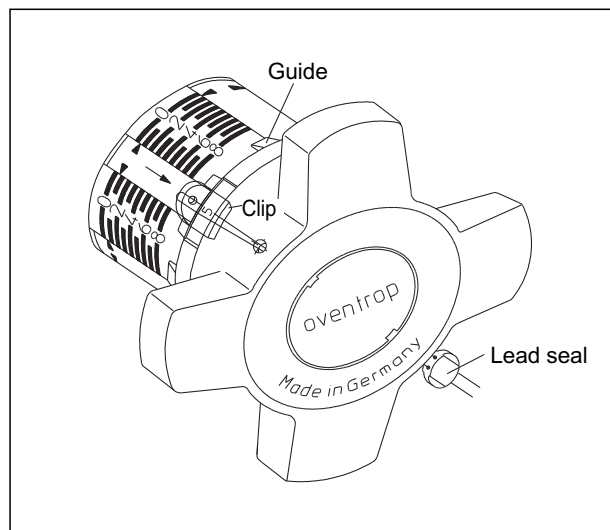
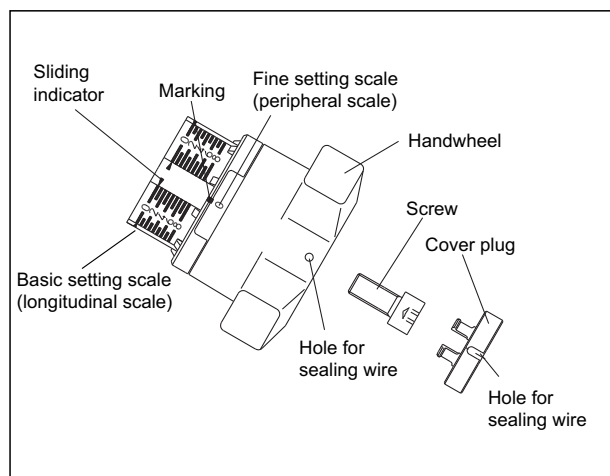

**Double regulating and commissioning valve  
8" - 12"**

**Measuring technic "classic"**

**Tender specification:**

Overtrop double regulating and commissioning valves with secured, infinitely adjustable presetting controllable at any time by use of the flow limiting device.

Sizes 8"-12"

Size	Item no.
8"	106 30 56
10"	106 30 57
12"	106 30 58

Lengths according to DIN EN 558-1 (basic series 1)

Valve body made of cast iron (EN-GJL-250 DIN EN 1561), bonnet made of nodular cast iron (EN-GJS-400 DIN EN 1563), bronze disc, stem made of brass resistant to dezincification. Disc with PTFE seal. Maintenance-free stem seal due to double EPDM O-ring. Groove connections for couplings. All functioning components on one level. Pressure test point and fill and drain ball valve interchangeable.

**Presetting 8"-12":**

- The value of presetting of the valve is adjusted by turning the handwheel.
  - The complete 12 turns of the handwheel are shown by the outer display.
  - 1/10th of a turn of the handwheel is shown by the inner display.
- Remove cover plug by introducing a screwdriver in the slot and gently prising it off.
- With the valve at the required value of presetting, turn the inner adjustment stem clockwise until it seats. This can be done by using a 0.4" screwdriver.
- Refit cover plug.

**Protecting the setting:**

A sealing wire may be fitted through the hole in the handwheel and a lead seal be fitted.

**Locking the handwheel:**

The handwheel can be locked in any position (display 1/10th of a turn) by removing the existing cover plug and replacing it with a special one. The sealing wire is then fitted through the hole in the handwheel and a lead seal is fitted.

**Dimensions:**

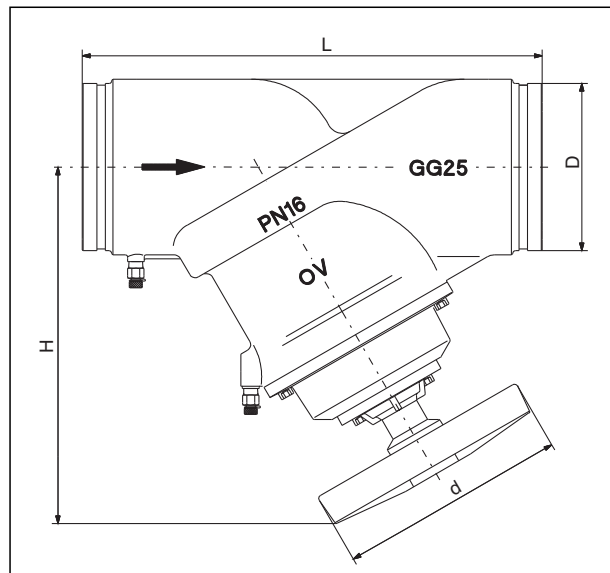

Size	L	D	H	d	Item no.
8"	23.62	8 5/8"	18.39	11.81	106 30 56
10"	28.74	10.75	18.9	11.81	106 30 57
12"	33.46	12.75	20.28	11.81	106 30 58

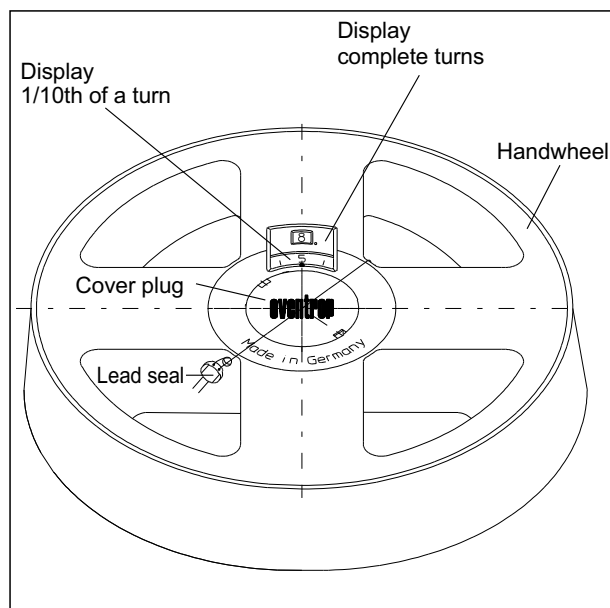

2 1/2"

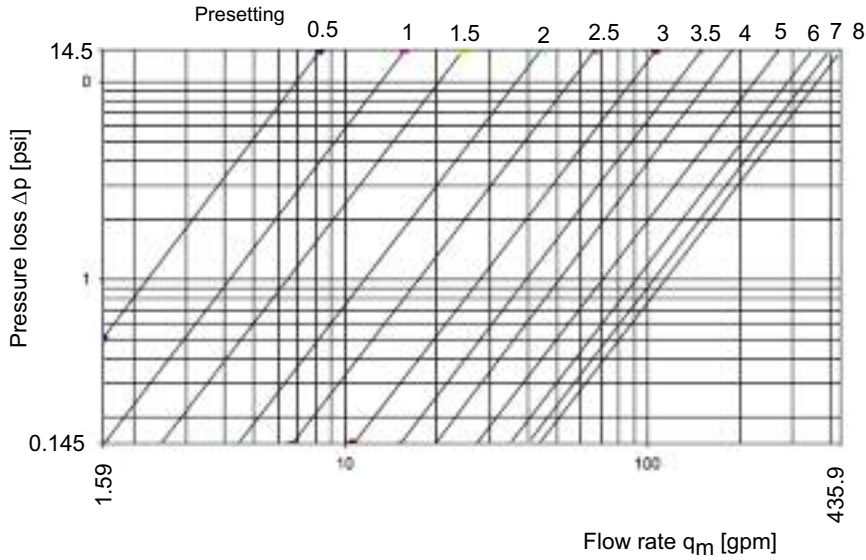

Presetting	c <sub>v</sub> values	Zeta values	Presetting	c <sub>v</sub> values	Zeta values
0.5	2.21	8454	5.0	70.93	8.2
1.0	4.19	2355	5.1	73.5	7.6
1.1	4.79	1798	5.2	75.5	7.2
1.2	5.22	1514	5.3	77.48	6.9
1.3	5.65	1292	5.4	79.44	6.5
1.4	6.08	1116	5.5	81.40	6.2
1.5	6.51	973	5.6	83.36	5.9
1.6	7.48	738	5.7	85.27	5.7
1.7	8.48	574	5.8	87.13	5.4
1.8	9.5	457	5.9	88.93	5.2
1.9	10.55	371	6.0	90.70	5.0
2.0	11.63	305	6.1	92.42	4.8
2.1	12.73	255	6.2	94.08	4.7
2.2	13.85	215	6.3	95.71	4.5
2.3	15.02	183	6.4	97.29	4.4
2.4	16.21	157	6.5	98.84	4.2
2.5	17.44	136	6.6	100.14	4.1
2.6	19.37	110	6.7	101.40	4.0
2.7	21.37	90	6.8	102.59	3.9
2.8	23.42	75	6.9	103.76	3.8
2.9	25.52	63	7.0	104.65	3.8
3.0	27.91	53	7.1	105.97	3.7
3.1	29.92	46	7.2	107	3.6
3.2	32.21	40	7.3	108.01	3.5
3.3	34.58	35	7.4	108.97	3.5
3.4	37.02	30	7.5	109.88	3.4
3.5	39.53	26	7.6	110.78	3.4
3.6	41.78	24	7.7	111.63	3.3
3.7	44.0	21	7.8	112.44	3.2
3.8	46.21	19	7.9	113.21	3.1
3.9	48.41	18	8.0	113.95	3.0
4.0	50.58	16			
4.1	52.74	15			
4.2	54.88	14			
4.3	57.01	13			
4.4	59.13	12			
4.5	60.47	11			
4.6	63.31	10			
4.7	65.38	10			
4.8	67.44	9.1			
4.9	69.47	8.6			

Zeta values related to the inner pipe diameter according to DIN 2448 (DIN ISO 4200) (66.1 mm)

3"

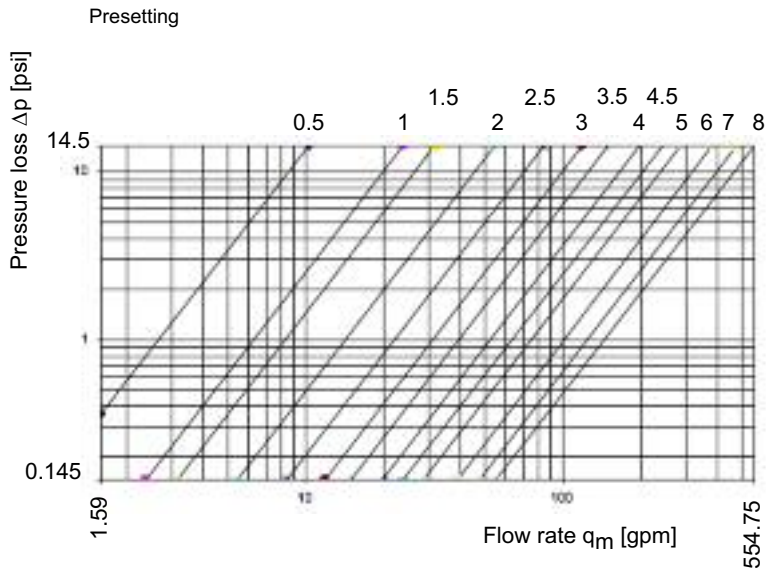

Presetting	c <sub>v</sub> values	Zeta values	Presetting	c <sub>v</sub> values	Zeta values
0.5	2.67	11016	5.0	75.12	14
1.0	5.12	3010	5.1	77.88	13
1.1	5.51	2594	5.2	80.60	12
1.2	6.01	2180	5.3	83.29	11
1.3	6.59	1813	5.4	85.93	11
1.4	7.3	1478	5.5	87.73	10
1.5	8.14	1189	5.6	91.13	9.5
1.6	9.17	936	5.7	93.67	9.0
1.7	10.26	749	5.8	96.19	8.5
1.8	11.37	609	5.9	98.66	8.1
1.9	12.55	500	6.0	101.16	7.7
2.0	13.78	415	6.1	103.53	7.4
2.1	15.06	347	6.2	105.81	7.0
2.2	16.41	293	6.3	108.29	6.7
2.3	17.83	248	6.4	110.63	6.4
2.4	19.31	211	6.5	113.43	6.1
2.5	21.69	168	6.6	115.23	5.9
2.6	22.55	155	6.7	117.49	5.7
2.7	24.30	133	6.8	119.72	5.5
2.8	26.17	115	6.9	121.94	5.3
2.9	28.19	99	7.0	124.13	5.1
3.0	30.35	86	7.1	126.03	5.0
3.1	32.38	75	7.2	127.91	4.8
3.2	34.43	66	7.3	129.77	4.7
3.3	36.50	59	7.4	131.40	4.6
3.4	38.59	53	7.5	133.14	4.4
3.5	40.70	48	7.6	135.03	4.3
3.6	42.83	43	7.7	136.95	4.2
3.7	44.98	39	7.8	138.69	4.1
3.8	47.15	35	7.9	140.40	4.0
3.9	49.34	32	8.0	142.09	3.9
4.0	52.03	29			
4.1	53.80	27			
4.2	56.06	25			
4.3	58.36	23			
4.4	60.67	21			
4.5	64.19	19			
4.6	65.37	18			
4.7	67.77	17			
4.8	70.19	16			
4.9	72.64	15			

Zeta values related to the inner pipe diameter according to DIN 2448 (DIN ISO 4200) (77.7 mm)

4"

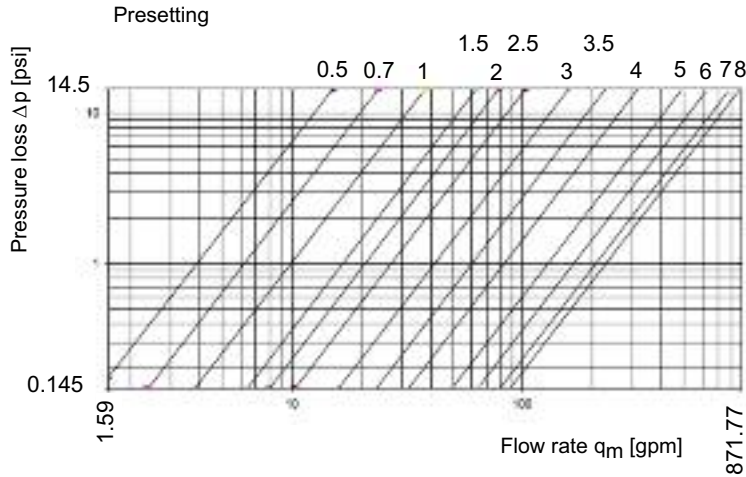

Presetting	c <sub>v</sub> values	Zeta values	Presetting	c <sub>v</sub> values	Zeta values
0.5	6.4	12904			
0.7	9.63	5694			
1.0	14.48	2518	5.0	149.13	24
1.1	16.09	2038	5.1	155.55	22
1.2	17.71	1683	5.2	162.26	20
1.3	19.33	1413	5.3	169.3	18
1.4	20.94	1203	5.4	176.7	17
1.5	22.56	1037	5.5	184.53	15
1.6	24.35	890	5.6	190.81	14
1.7	26.13	773	5.7	197.21	13.5
1.8	27.92	677	5.8	203.73	12.7
1.9	29.70	598	5.9	210.4	11.9
2.0	30.93	552	6.0	215.47	11.4
2.1	33.27	477	6.1	224.13	10.5
2.2	35.06	429	6.2	231.22	9.9
2.3	36.84	389	6.3	238.49	9.3
2.4	38.63	354	6.4	245.93	8.7
2.5	40.41	323	6.5	253.55	8.2
2.6	43.23	282	6.6	259.73	7.8
2.7	46.15	248	6.7	265.86	7.5
2.8	49.17	218	6.8	271.97	7.1
2.9	52.29	193	6.9	277.94	6.8
3.0	55.52	171	7.0	283.9	6.5
3.1	58.87	152	7.1	289.8	6.3
3.2	62.35	136	7.2	295.65	6.0
3.3	65.97	121	7.3	301.45	5.8
3.4	69.77	108	7.4	307.2	5.6
3.5	73.66	97	7.5	311.8	5.4
3.6	77.47	88	7.6	318.55	5.2
3.7	81.4	80	7.7	324.15	5.0
3.8	85.5	72	7.8	329.71	4.9
3.9	89.78	65	7.9	334.84	4.7
4.0	94.24	59	8.0	340.7	4.5
4.1	98.92	54			
4.2	103.84	49			
4.3	109.03	44			
4.4	114.53	40			
4.5	120.41	36			
4.6	125.77	33			
4.7	131.3	31			
4.8	137.02	28			
4.9	142.97	26			

Zeta values related to the inner pipe diameter according to DIN 2448 (DIN ISO 4200) (100.8 mm)

5"

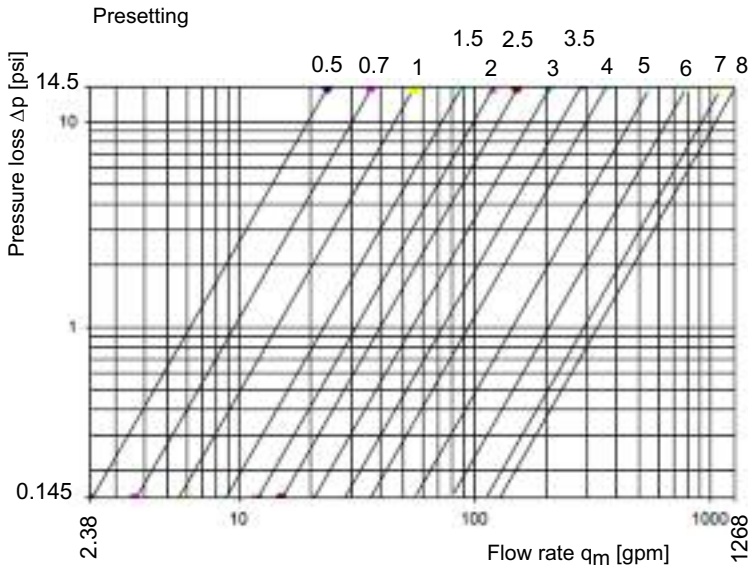

Presetting	c <sub>v</sub> values	Zeta values	Presetting	c <sub>v</sub> values	Zeta values
0.5	6.40	12904			
0.7	9.63	5694			
1.0	14.48	2518	5.0	149.13	24
1.1	16.09	2038	5.1	155.55	22
1.2	17.71	1683	5.2	162.26	20
1.3	19.33	1413	5.3	169.30	18
1.4	20.94	1203	5.4	176.70	17
1.5	22.56	1037	5.5	184.53	15
1.6	24.35	890	5.6	190.81	14
1.7	26.13	773	5.7	197.21	13.5
1.8	27.92	677	5.8	203.73	12.7
1.9	29.70	598	5.9	210.40	11.9
2.0	30.93	552	6.0	215.47	11.4
2.1	33.27	477	6.1	224.13	10.5
2.2	35.06	429	6.2	231.22	9.9
2.3	36.84	389	6.3	238.49	9.3
2.4	38.63	354	6.4	245.93	8.7
2.5	40.41	323	6.5	253.55	8.2
2.6	43.23	282	6.6	259.73	7.8
2.7	46.15	248	6.7	265.86	7.5
2.8	49.17	218	6.8	271.97	7.1
2.9	52.29	193	6.9	277.94	6.8
3.0	55.52	171	7.0	283.90	6.5
3.1	58.87	152	7.1	289.80	6.3
3.2	62.35	136	7.2	295.65	6.0
3.3	65.97	121	7.3	301.45	5.8
3.4	69.77	108	7.4	307.20	5.6
3.5	73.66	97	7.5	311.80	5.4
3.6	77.47	88	7.6	318.55	5.2
3.7	81.40	80	7.7	324.15	5.0
3.8	85.50	72	7.8	329.71	4.9
3.9	89.78	65	7.9	334.84	4.7
4.0	94.24	59	8.0	340.70	4.5
4.1	98.92	54			
4.2	103.84	49			
4.3	109.03	44			
4.4	114.53	40			
4.5	120.41	36			
4.6	125.77	33			
4.7	131.30	31			
4.8	137.02	28			
4.9	142.97	26			

Zeta values related to the inner pipe diameter according to DIN 2448 (DIN ISO 4200) (125 mm)

6"

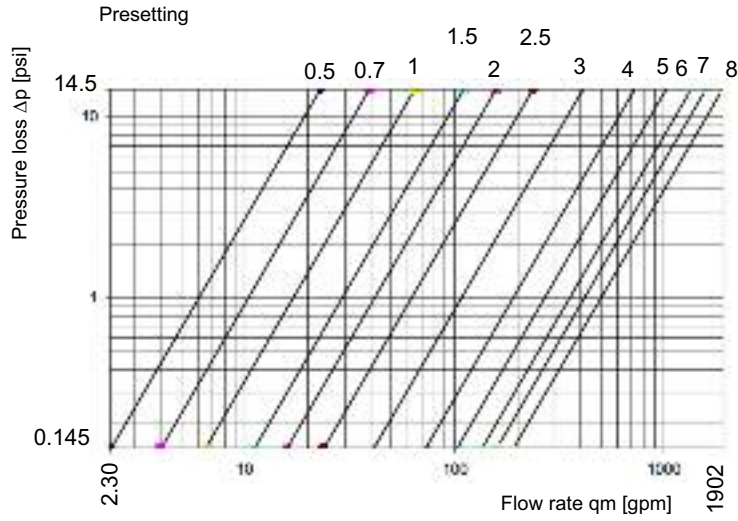

Presetting	C <sub>V</sub> values	Zeta values	Presetting	C <sub>V</sub> values	Zeta values
0.5	6.05	29934			
0.7	10.71	9542			
1.0	17.7	3494	5.0	277.8	14.0
1.1	20.02	2730	5.1	284.56	13.5
1.2	22.36	2189	5.2	292.09	12.8
1.3	24.69	1796	5.3	299.53	12.2
1.4	27.02	1499	5.4	306.86	11.6
1.5	29.37	1269	5.5	316.74	10.9
1.6	31.67	1091	5.6	321.21	10.6
1.7	34.3	930	5.7	328.26	10.2
1.8	36.34	829	5.8	335.2	9.7
1.9	38.67	732	5.9	342.06	9.4
2.0	41.0	651	6.0	349.3	9.0
2.1	43.17	587	6.1	355.53	8.8
2.2	45.83	521	6.2	362.15	8.4
2.3	49.19	452	6.3	368.7	8.1
2.4	53.78	378	6.4	374.5	7.8
2.5	62.7	278	6.5	379.88	7.6
2.6	70.93	218	6.6	387.88	7.3
2.7	79.71	172	6.7	393.42	7.1
2.8	89.12	138	6.8	400.34	6.8
2.9	99.3	111	6.9	406.47	6.6
3.0	110.49	90	7.0	413.49	6.4
3.1	122.69	73	7.1	418.6	6.2
3.2	133.08	62	7.2	424.49	6.1
3.3	142.28	54	7.3	430.38	5.9
3.4	150.6	48	7.4	436.22	5.8
3.5	157.5	44	7.5	444.19	5.6
3.6	165.36	40	7.6	447.72	5.5
3.7	171.41	37	7.7	452.71	5.3
3.8	178.29	34	7.8	458.37	5.2
3.9	186.05	32	7.9	464.58	5.1
4.0	194.33	29	8.0	470.12	5.0
4.1	202.88	27			
4.2	211.35	25			
4.3	219.83	23			
4.4	228.3	21			
4.5	236.8	20			
4.6	245.09	18			
4.7	253.24	17			
4.8	260.63	16			
4.9	269.14	15			

Zeta values related to the inner pipe diameter according to DIN 2448 (DIN ISO 4200) (150 mm)

Flow tolerances depending on the presetting for 2 1/2"-6"

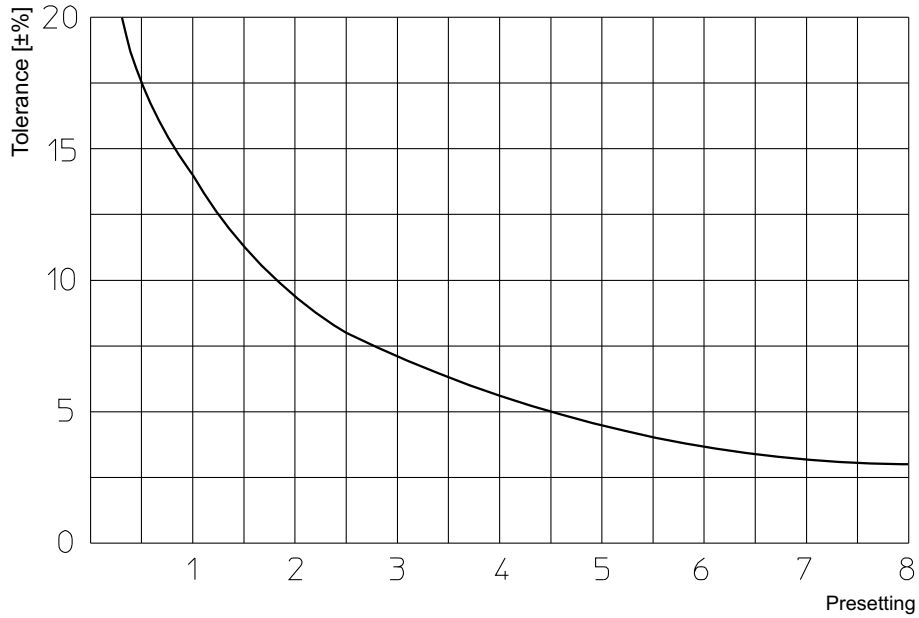

8"

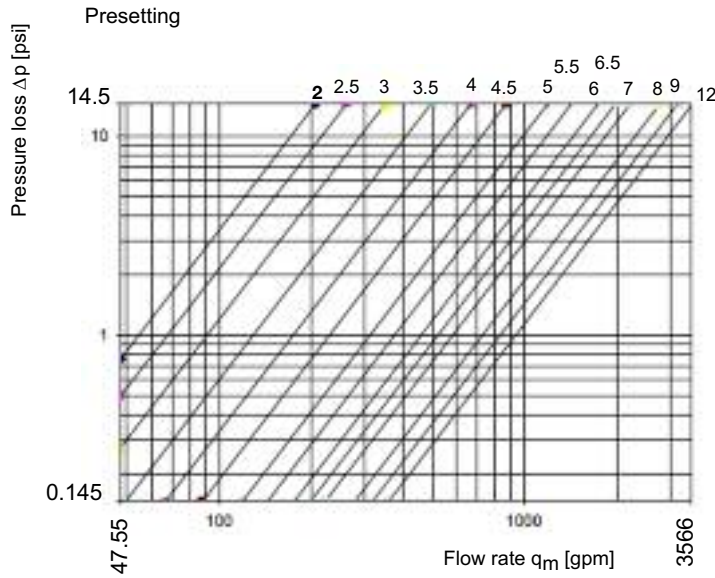

Presetting	Cv values	Zeta values	Presetting	Cv values	Zeta values
2.0	58.86	1191	7.0	592.44	11
2.1	60.00	1070	7.1	603.95	11
2.2	63.02	969	7.2	615.47	10
2.3	66.05	883	7.3	626.98	10
2.4	69.07	807	7.4	638.49	9
2.5	72.09	741	7.5	650.0	9
2.6	77.21	646	7.6	663.95	9
2.7	82.33	568	7.7	677.33	8
2.8	87.44	504	7.8	690.93	8
2.9	92.56	449	7.9	704.65	8
3.0	97.67	404	8.0	718.6	7
3.1	104.65	352	8.1	728.84	7
3.2	111.63	309	8.2	738.14	7
3.3	118.6	274	8.3	737.44	7
3.4	125.58	244	8.4	757.67	7
3.5	132.56	219	8.5	767.44	7
3.6	140.7	195	8.6	782.33	6
3.7	149.77	172	8.7	796.74	6
3.8	158.37	154	8.8	812.44	6
3.9	166.98	138	8.9	827.44	6
4.0	175.58	125	9.0	842.44	6
4.1	188.37	109	9.1	850.47	5
4.2	201.16	95	9.2	858.37	5
4.3	213.95	84	9.3	866.16	5
4.4	226.74	75	9.4	874.07	5
4.5	239.53	67	9.5	881.98	5
4.6	252.09	61	9.6	884.42	5
4.7	264.65	55	9.7	886.86	5
4.8	277.21	50	9.8	889.3	5
4.9	289.77	46	9.9	891.74	5
5.0	302.67	41	10.0	894.19	5
5.1	316.16	38	10.1	896.74	5
5.2	330.0	35	10.2	899.3	5
5.3	343.72	33	10.3	901.86	5
5.4	357.56	30	10.4	904.65	5
5.5	372.09	28	10.5	906.98	5
5.6	386.05	26	10.6	909.3	5
5.7	400.93	24	10.7	911.63	5
5.8	415.81	22	10.8	913.95	5
5.9	430.58	21	10.9	916.28	5
6.0	445.35	19	11.0	918.6	5
6.1	460.47	18	11.1	921.16	5
6.2	475.58	17	11.2	923.84	5
6.3	490.7	16	11.3	926.51	5
6.4	505.81	15	11.4	929.19	4
6.5	520.70	14	11.5	931.86	4
6.6	534.88	13	11.6	934.88	4
6.7	549.42	13	11.7	937.91	4
6.8	563.72	12	11.8	940.93	4
6.9	578.14	12	11.9	944.19	4
			12.0	947.09	4

Zeta values related to the inner pipe diameter according to DIN 2448 (DIN ISO 4200) (207.3 mm)

10"

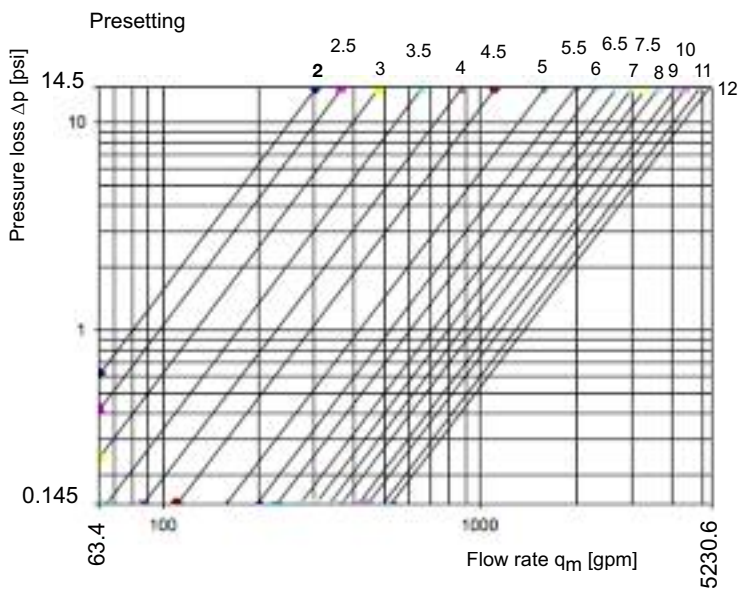

Presetting	Cv values	Zeta values	Presetting	Cv values	Zeta values
2.0	81.4	1318	7.0	793.02	14
2.1	84.3	1229	7.1	811.63	13
2.2	87.79	1133	7.2	830.23	13
2.3	91.86	1035	7.3	847.67	12
2.4	95.35	961	7.4	866.28	12
2.5	98.84	894	7.5	883.72	11
2.6	104.07	806	7.6	904.65	11
2.7	109.3	731	7.7	924.42	10
2.8	115.12	659	7.8	943.02	10
2.9	121.51	592	7.9	960.47	10
3.0	127.91	534	8.0	976.74	9
3.1	136.05	472	8.1	988.37	9
3.2	143.6	424	8.2	1000	9
3.3	151.74	379	8.3	1011.63	8
3.4	161.63	334	8.4	1023.26	8
3.5	174.42	287	8.5	1034.88	8
3.6	180.23	269	8.6	1045.35	8
3.7	190.7	240	8.7	1054.65	8
3.8	202.33	213	8.8	1065.12	8
3.9	213.95	191	8.9	1075.58	8
4.0	226.74	170	9.0	1084.88	7
4.1	241.86	149	9.1	1095.35	7
4.2	256.98	132	9.2	1106.98	7
4.3	274.42	116	9.3	1117.44	7
4.4	293.02	102	9.4	1127.91	7
4.5	313.95	89	9.5	1139.53	7
4.6	333.72	78	9.6	1150	7
4.7	353.49	70	9.7	1160.47	6
4.8	373.26	63	9.8	1172.09	6
4.9	393.02	57	9.9	1183.72	6
5.0	413.95	51	10.0	1195.35	6
5.1	433.72	46	10.1	1206.98	6
5.2	453.49	42	10.2	1218.6	6
5.3	473.26	39	10.3	1231.4	6
5.4	491.86	36	10.4	1245.35	6
5.5	511.63	33	10.5	1255.81	6
5.6	531.4	31	10.6	1265.12	5
5.7	550.0	29	10.7	1274.42	5
5.8	569.77	27	10.8	1283.72	5
5.9	588.37	25	10.9	1293.02	5
6.0	606.98	24	11.0	1302.33	5
6.1	626.74	22	11.1	1311.63	5
6.2	645.35	21	11.2	1320.93	5
6.3	663.95	20	11.3	1330.23	5
6.4	682.56	19	11.4	1339.53	5
6.5	705.81	18	11.5	1348.94	5
6.6	719.77	17	11.6	1358.14	5
6.7	738.37	16	11.7	1367.44	5
6.8	756.98	15	11.8	1376.74	5
6.9	774.42	15	11.9	1386.05	4
			12.0	1395.35	4

Zeta values related to the inner pipe diameter according to DIN 2448 (DIN ISO 4200) (10")

12"

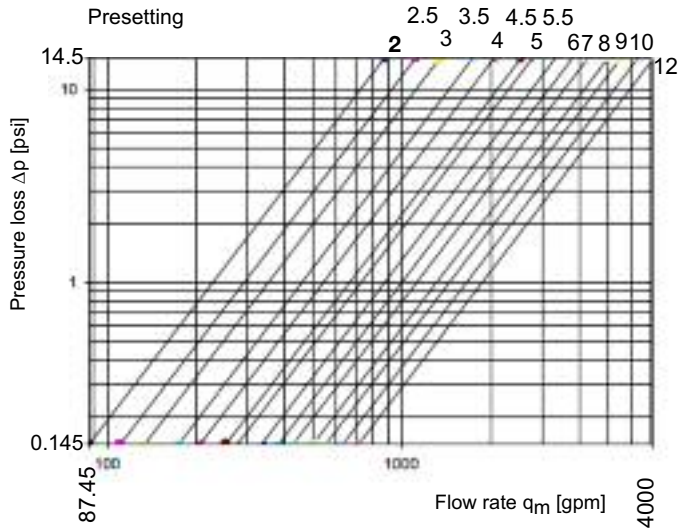

Presetting	Cv values	Zeta values	Presetting	Cv values	Zeta value
2.0	232.56	325	7.0	1151.16	13
2.1	244.19	295	7.1	1168.6	13
2.2	255.81	269	7.2	1186.05	12
2.3	267.44	246	7.3	1204.65	12
2.4	279.07	226	7.4	1224.42	12
2.5	290.7	208	7.5	1244.19	11
2.6	303.49	191	7.6	1260.47	11
2.7	317.44	174	7.7	1276.74	11
2.8	331.4	160	7.8	1293.02	11
2.9	345.35	147	7.9	1309.3	10
3.0	360.47	135	8.0	1325.58	10
3.1	375.58	125	8.1	1341.86	10
3.2	390.7	115	8.2	1358.14	10
3.3	406.98	106	8.3	1374.42	9
3.4	424.42	98	8.4	1390.7	9
3.5	441.86	90	8.5	1406.98	9
3.6	466.28	81	8.6	1427.91	9
3.7	489.53	73	8.7	1447.67	8
3.8	512.79	67	8.8	1466.28	8
3.9	536.05	61	8.9	1483.72	8
4.0	558.14	56	9.0	1500	8
4.1	580.23	52	9.1	1515.12	8
4.2	601.16	49	9.2	1530.23	8
4.3	622.09	45	9.3	1544.19	7
4.4	643.02	43	9.4	1556.98	7
4.5	662.79	40	9.5	1569.77	7
4.6	683.72	38	9.6	1587.21	7
4.7	704.65	35	9.7	1603.49	7
4.8	725.58	33	9.8	1619.77	7
4.9	746.51	32	9.9	1636.05	7
5.0	767.44	30	10.0	1651.16	6
5.1	788.37	28	10.1	1666.28	6
5.2	809.3	27	10.2	1681.40	6
5.3	830.23	26	10.3	1694.19	6
5.4	837.21	24	10.4	1706.98	6
5.5	872.09	23	10.5	1720.93	6
5.6	896.51	22	10.6	1732.56	6
5.7	919.77	21	10.7	1744.19	6
5.8	941.86	20	10.8	1755.81	6
5.9	962.79	19	10.9	1767.44	6
6.0	982.56	18	11.0	1779.07	6
6.1	1001.16	18	11.1	1789.53	5
6.2	1019.77	17	11.2	1798.84	5
6.3	1037.21	16	11.3	1808.14	5
6.4	1053.49	16	11.4	1817.04	5
6.5	1069.77	15	11.5	1825.58	5
6.6	1084.88	15	11.6	1833.72	5
6.7	1101.16	14	11.7	1840.7	5
6.8	1117.44	14	11.8	1847.67	5
6.9	1133.72	14	11.9	1854.65	5
			12.0	1600.0	5

Zeta values related to the inner pipe diameter according to DIN 2448 (DIN ISO 4200) (300 mm)

Flow tolerances depending on the presetting for 8" – 12"

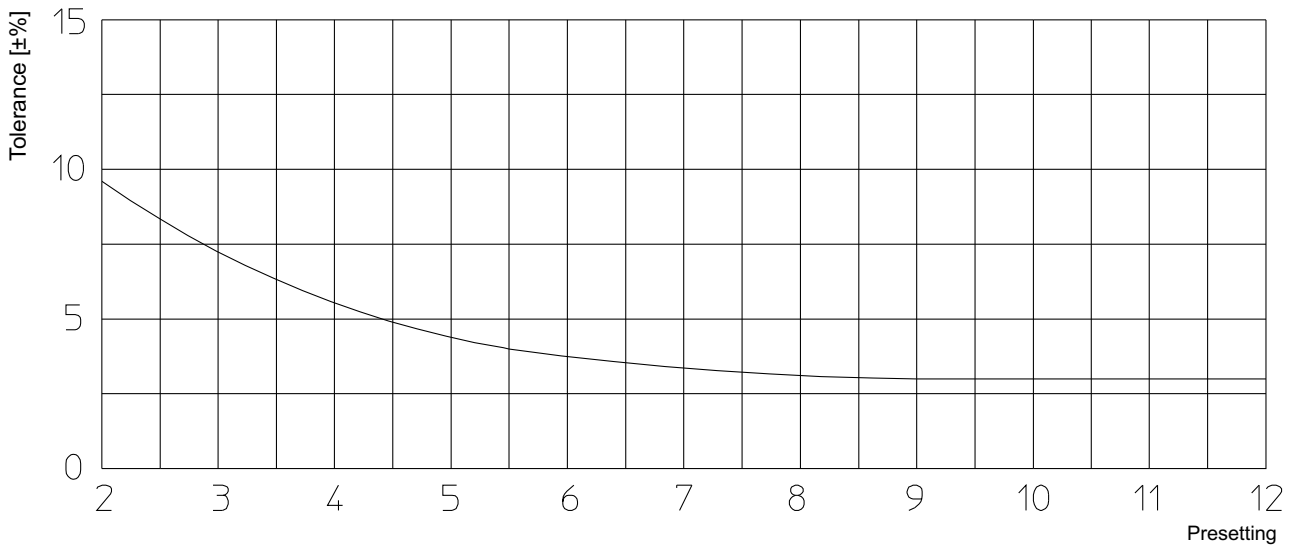



**Insulation shells 2 1/2" – 8"**

**Tender specification:**

The insulation shells have a CFC-free inner core made of polyurethane foam with a 1.5 mm plastic coat. It consists of two double shells which are tightened by two metal straps.

- Size
- 2 1/2"
- 3"
- 4"
- 5"
- 6"
- 8"

- Item no.
- 106 25 86
- 106 25 87
- 106 25 88
- 106 25 89
- 106 25 90
- 106 25 91

**2 1/2" – 3"**

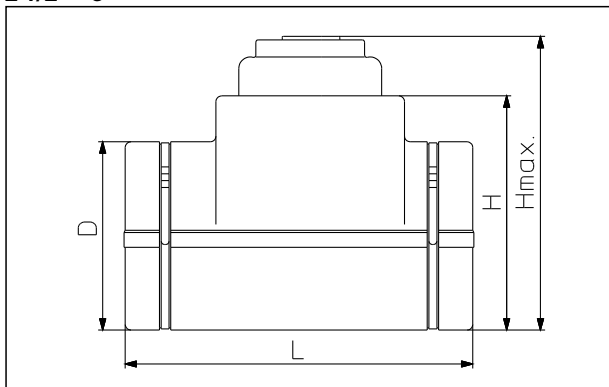

**4" – 8"**

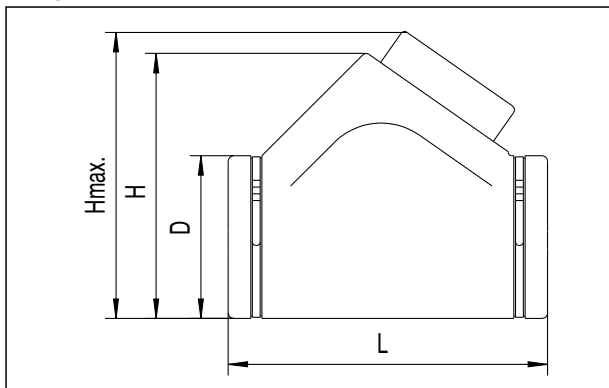

Size	L	D	H max.	H	Item no.
2 1/2"	19.88	10.24	16.14	11.42	106 25 86
3"	20.87	11.02	16.34	12.4	106 25 87
4"	22.83	12.6	20.47	14.96	106 25 88
5"	24.41	14.17	22.05	16.54	106 25 89
6"	28.74	15.75	23.62	18.11	106 25 90
8"	31.5	17.72	29.92	25.59	106 25 91

**Correction factor for mixtures of water and glycol:**

When antifreeze liquids are added to the heating water, the pressure loss given in the chart must be multiplied by the correction factor f.

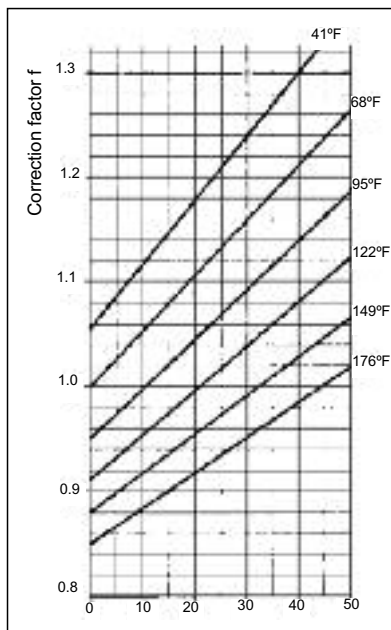

Weight proportion of ethylene glycol [%]

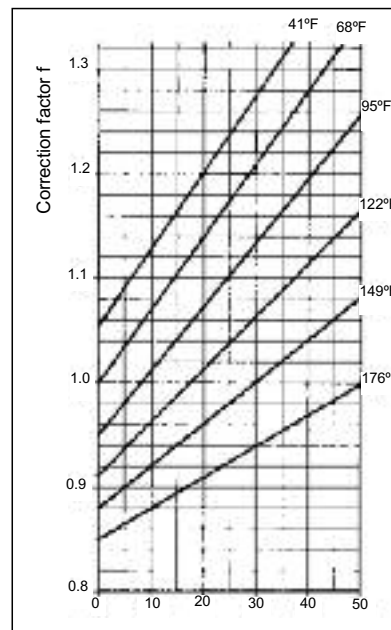

Weight proportion of propylene glycol [%]

## Measurement and regulation 2 1/2" – 12"

### Oventrop flow-meter "OV-DMC 2" with memory and microprocessor



Flow meter "OV-DMC 2" item no. 106 91 77  
with „Hydrocontrol G" 2 1/2"

featuring numerous functions and a wide range of applications:

- flow rate indication (l/s, m<sup>3</sup>/h and gal/min.)
- differential pressure measuring (indication in mbar, Pa or kPa)
- temperature measuring (indication in °C or °F)
- presetting. Arriving at the value of presetting based on the measured differential pressure, the given flowrate and the valve size.

The characteristic lines of all Oventrop double regulating and commissioning valves DN 10 – 12" are memorised in the "OV-DMC".

By introducing the corresponding kv value, it is possible to carry out all measurements on valves of other manufacturers.

(For practical use of the "OV-DMC 2", special operating instructions are available.)