

### General Specifications for all types and models

Manufactured in the United States of America

Oventrop **Solar Storage Tank**  
316 Stainless steel construction  
with integrated tubular heat exchanger

### Materials specifications

- 1) Tank insulation: 2 inch, R-12 soft foam
- 2) Heat exchanger coil construction:
  - A) Non-finned tubing
  - B) 316 Stainless
  - C) 1 inch connections
- 3) Tank wall type: Single wall
- 4) Tank material: 316 stainless steel
- 5) Pressure relief and drain valves: Pre-installed

### Operating specifications

- 1) Max Operating pressure: 150 psi
- 2) Connection port location: Top of tank
- 3) Max. Operating Temperature: 200 degrees fahrenheit

### Installation spacing specifications

	Service Clearance	Combustible Surfaces Clearance
Bottom	0"	0"
Left, Right, and Rear Sides	3"	1"
Front	30"	1"
Top	6"	6"

### Solar Water Heater Sizing

Choose the solar water heater model based on the daily hot water usage for the given site. Factors that increase hot water demand dramatically include high flow shower heads, hot tubs, and the use of more than one shower at a time. Increase the tank size if these factors are present. Consult ASHRAE sizing guides and other references.



Type: Dual Coil Model Series: 540 0X XX DC

Oventrop Solar Storage Tank  
 316 Stainless steel construction  
 with integrated tubular heat exchanger

**Top Boiler Coil Heat Exchanger Output Ratings**

**Table 2a**

Model	60 Gallon 540 00 60			
Boiler Output	1st Hour Rating		Continuous Rating	
BTU/Hr	US Gal/Hr		US Gal/Hr	
	140 F	115 F	140 F	115 F
50,000	121	146	67	92
60,000	134	165	80	111
80,000	161	201	107	147
100,000	187	238	133	184
120,000	214	275	160	221
140,000	214	312	160	258
160,000	214	312	160	258

**Table 2b**

Model	80 Gallon 540 00 80			
Boiler Output	1st Hour Rating		Continuous Rating	
BTU/hr	US Gal/Hr		US Gal/Hr	
	140 F	115 F	140 F	115 F
50,000	139	164	67	92
60,000	152	183	80	111
80,000	179	219	107	147
100,000	205	256	133	184
120,000	232	293	160	221
140,000	232	330	160	258
160,000	232	330	160	258

**Table 2c**

Model	115 Gallon 540 01 15			
Boiler Output	1st Hour Rating		Continuous Rating	
BTU/Hr	US Gal/Hr		US Gal/Hr	
	140 F	115 F	140 F	115 F
50,000	139	164	67	92
60,000	152	183	80	111
80,000	179	219	107	147
100,000	205	256	133	184
120,000	232	293	160	221
140,000	232	330	160	258
160,000	232	330	160	258
180,000	273	365	170	265

**Table 2d**

Model	540 00 60	540 00 80	540 01 15
Minimum Flow Rate	10 gpm	10 gpm	10 gpm
Pressure Drop at Minimum Flow Rate	3.9 ft/hd	3.0 ft/hd	3.0 ft/hd

Minimum Flow Rate is for Boiler Coil only.

Tables 2a - c assume boiler input water temperature of 180 degrees Fahrenheit

# oventrop

## Technical Product Submittal

Type: Dual Coil Model Series: 540 0X XX DC

Oventrop **Solar Storage Tank**  
316 Stainless steel construction  
with integrated tubular heat exchanger

### Dimensioned Drawing

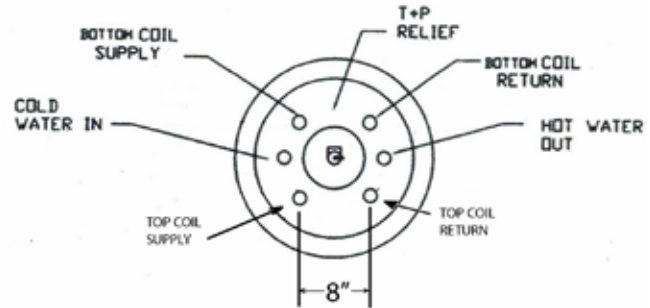
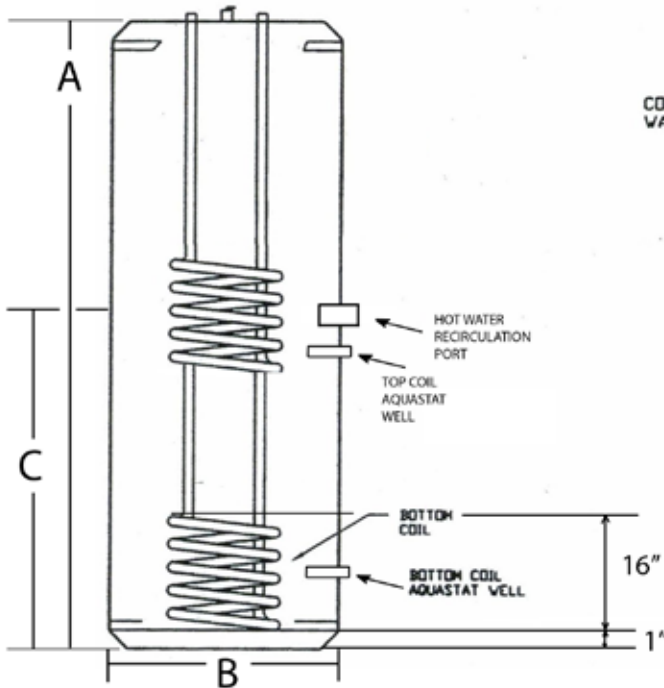

Coil Inner Diameter - 11.5"  
Coil Outer Diameter - 13.5"  
Coil Pitch - 1 1/8"  
Height - 16"  
Coil Tube - 1 1/8" OD  
Coil Wall Thickness - 0.049" [16 Ga.]  
Coil Material - 316L Stainless Steel

Model	Weight	Volume	Diameter	Height
540 00 60	150 lbs.	60 gal.	22.5 inches	60 inches
540 00 80	165 lbs.	80 gal.	26.5 inches	54 inches
540 01 15	198 lbs.	115 gal.	26.5 inches	72 inches

### Theoretical Piping Schematic

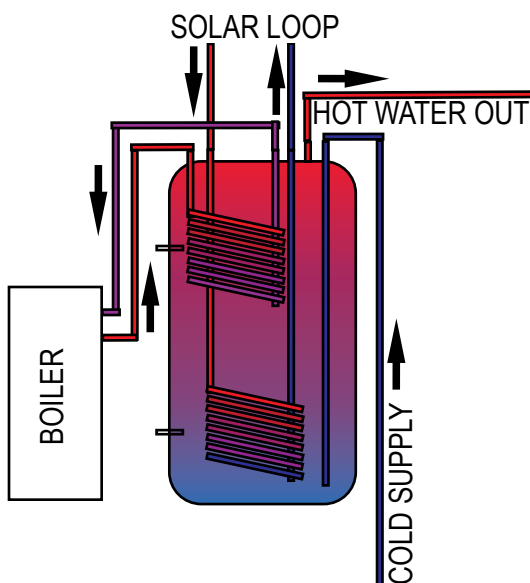

Dimension	Size
A	Height
B	Diameter
C	50% of Height

The top coil is piped to a boiler in the same manner as a standard indirect water heating tank.  
The bottom coil is piped to the "Regusol" pumping station.

# oventrop

## Technical Product Submittal

Type: Single Coil Model Series: 540 0X XX SC

Oventrop **Solar Storage Tank**  
316 Stainless steel construction  
with integrated tubular heat exchanger

### Dimensioned Drawing

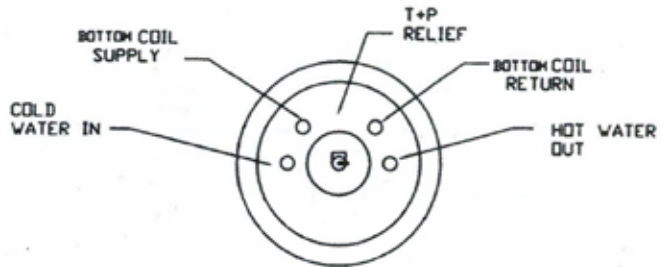
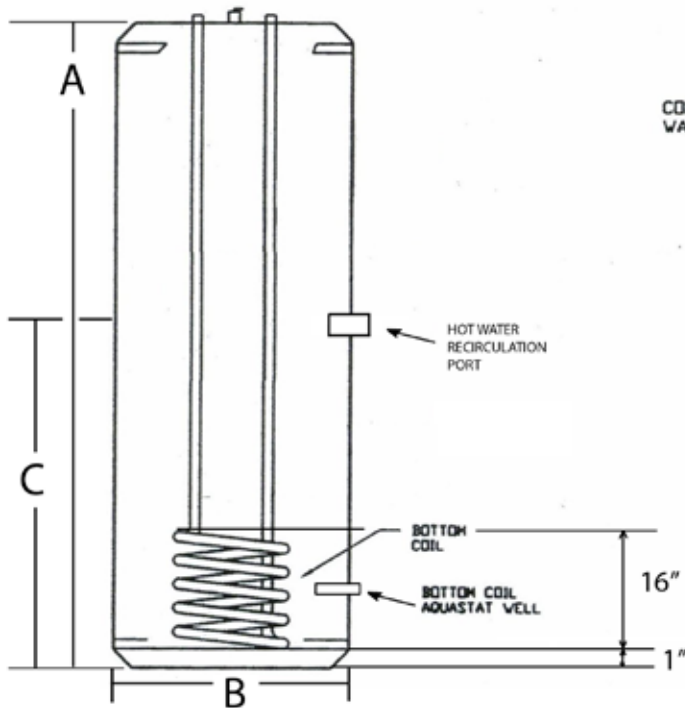

Coil Inner Diameter - 11.5"  
Coil Outer Diameter - 13.5"  
Coil Pitch - 1 1/8"  
Height - 16"  
Coil Tube - 1 1/8" OD  
Coil Wall Thickness - 0.049" [16 Ga.]  
Coil Material - 316L Stainless Steel

Model	Weight	Volume	Diameter	Height
540 00 60	150 lbs.	60 gal.	22.5 inches	60 inches
540 00 80	165 lbs.	80 gal.	26.5 inches	54 inches
540 01 15	198 lbs.	115 gal.	26.5 inches	72 inches

### Theoretical Piping Schematic

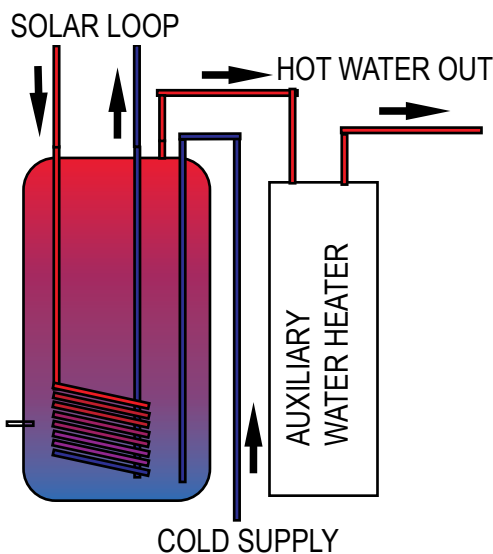

The bottom coil is piped to the "Regusol" pumping station.  
The hot water output of the solar storage tank is piped to the supply of the auxiliary water heater. The auxiliary water heater is piped into the system as standard.

Dimension	Size
A	Height
B	Diameter
C	50% of Height

# oventrop

## Technical Product Submittal

Type: Single Coil with Electric Element Backup

Model Series: 540 0X XX E

Oventrop **Solar Storage Tank**  
316 Stainless steel construction  
with integrated tubular heat exchanger

### Dimensioned Drawing

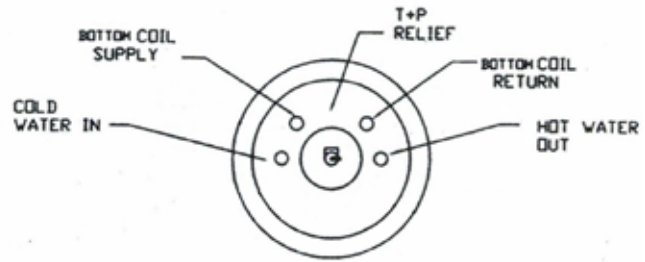
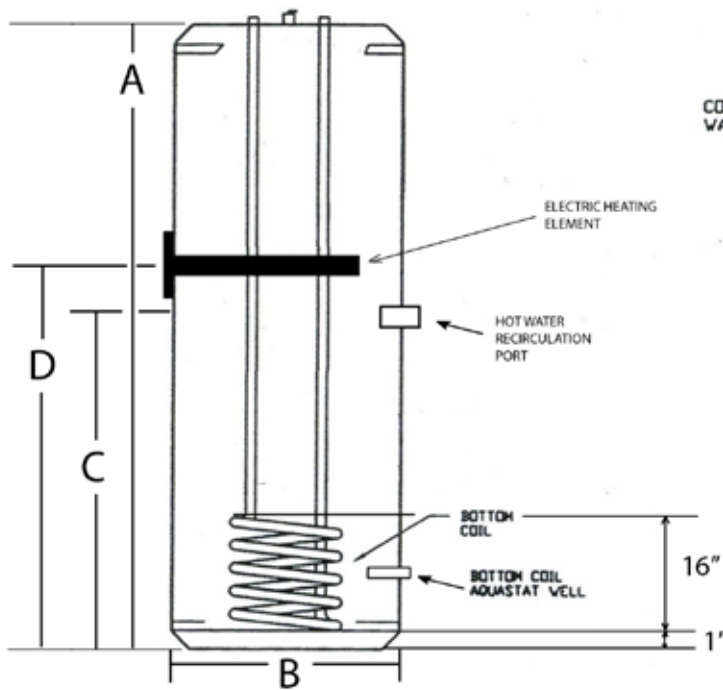

Coil Inner Diameter - 11.5"  
Coil Outer Diameter - 13.5"  
Coil Pitch - 1 1/8"  
Height - 16"  
Coil Tube - 1 1/8" OD  
Coil Wall Thickness - 0.049" [16 Ga.]  
Coil Material - 316L Stainless Steel

Model	Weight	Volume	Diameter	Height
540 00 60	150 lbs.	60 gal.	22.5 inches	60 inches
540 00 80	165 lbs.	80 gal.	26.5 inches	54 inches
540 01 15	198 lbs.	115 gal.	26.5 inches	72 inches

### Theoretical Piping Schematic

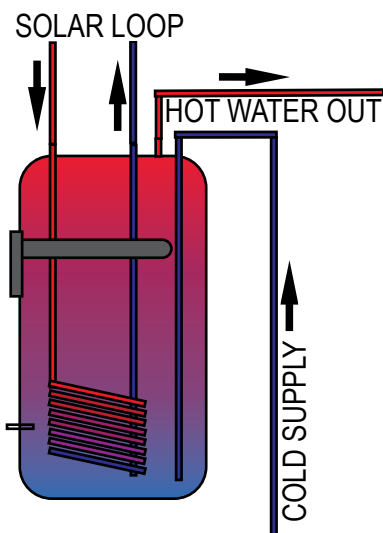

The bottom coil is piped to the "Regusol" pumping station.  
The hot water output is piped as a conventional electric water heater.

Dimension	Size
A	Height
B	Diameter
C	50% of Height
D	55% of Height