



Thermostatic radiator valves Thermostats "Uni LH" and "Uni LD"

Installation instructions

Contents:

Page 1 General information
Valve installation
Thermostat installation
Figures and symbols on the thermostat

Page 2 Limiting the control range

Page 3 Blocking the temperature setting
Recalibration
Cancellation of limitation or blocking

Page 4 Replacement of the gland nut
Checklist for faults
Supplier addresses

General information

Thermostatic radiator valves control the room temperature by modifying the flow of hot water through the radiator. Often, there is only a minimum requirement for heat (especially in transition periods) and so the thermostats only open the valves a small amount. Consequently flow noises could occur due to high differential pressures. To prevent these noises, measures should be taken to influence the differential pressure; for example by using adjustable circulation pumps, manually adjustable bypass pipes, differential pressure regulators or differential pressure relief valves.

It is recommended to adjust the temperature of the supply pipe to the outside temperature, preferably by using a weather guided temperature controller.

Fur further information see technical data sheets "Thermostats" and "Thermostatic radiator valves".

Valve installation

The radiator valve should be installed so that the thermostat is in a horizontal position and a good circulation of air is guaranteed. If this is not possible, a thermostat with remote sensor or with remote control should be used. It is most important that capillaries are not kinked or flattened.

The radiator valve is installed in the supply pipe to the radiator, with the flow in the direction of the arrow.

When using compression fitting, the thread of the fitting and the compression ring are slightly oiled at works. Do not use any additional lubricant! Do not allow the oil or lubricant to come into contact with the EPDM valve disc. EPDM is not oil resistant.

Only original Oventrop compression fittings should be used.

It is important that the pipes are cut to the correct length at a right angle to the centre line. The ends of the pipe must be free of burrs and undamaged.

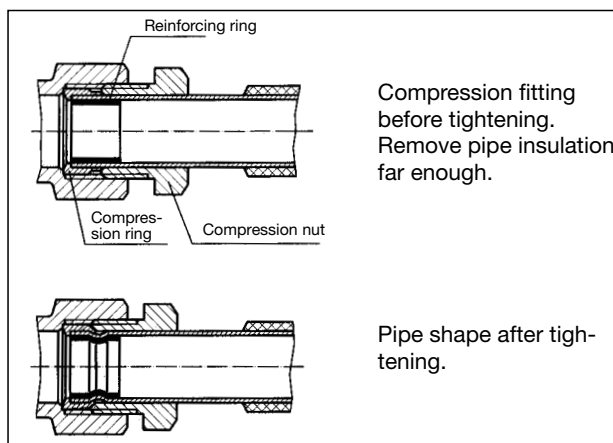

When using thin walled and very soft pipes, reinforcing sleeves have to be used. The reinforcing sleeve supports the pipe and provides the strength to enable the necessary compression. Reinforcing sleeves cannot be used on pipe with welded seams. The recommendations of the pipe manufacturers have to be observed in any case. If necessary, a practical test has to be carried out.

The special fittings "Cofit" may be used for the Oventrop composition pipe "Copipe". The installation instructions supplied with the fittings must be observed.

All radiators and pipework must be flushed thoroughly to prevent any problems caused by welding beads or dirt.

When converting old heating systems, it is recommended that a plastic strainer should be fitted at the inlet port of all radiator valves.

Do not fit the thermostat until all building work has been completed. During construction period, the valve can be operated with the screwed cap. The screwed cap is not to be used for permanent shut-off of the valve against system pressure (e.g. while radiator is removed). In this case protect the valve outlet with a metal cap.

Thermostat installation

To ensure an easy installation, the handgrip must be opened to the maximum position (figure "5"). In this position, the collar nut ("Uni LH") or the squeeze connection ("Uni LD") of the thermostat may be easily fitted to the valve body.

Turn the thermostat so that the indicator mark is facing up. Hold in this position and tighten collar nut without using excessive force.

Figures and symbols on the thermostat

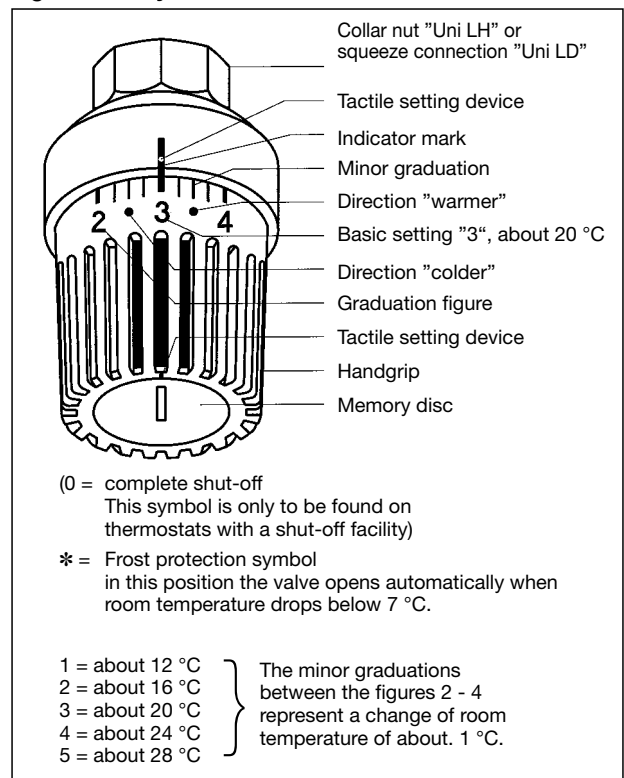

Limiting the control range

The control range of the thermostat can be limited with the clips attached to the inner side of the handgrip. The clips can only be inserted on the **inner side** of the handgrip. The two bridges of a clip have each to be inserted into two grooves of the inner framework.

E.g.: Limiting a control range to a minimum of 16 °C (figure "2") and a maximum of 24 °C (figure "4") (e.g. for living rooms, old peoples' homes).



1

Photo 1: Remove the handgrip with the tool (item no. 198 91 00) or with a pin, e.g. with the push button of a pen. Insert the tool/pin in the hole provided on the lower side of the thermostat. By turning the handgrip to the shut-off position, it is easily removed (compare photo 16).

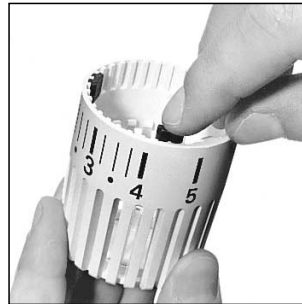

5

Photo 5: To limit the maximum control range, e.g. at figure "4" (equals approx. 24 °C), the second clip should be fitted into the groove immediately **after** figure "4". (The groove directly opposite figure "4" thus remains free.)

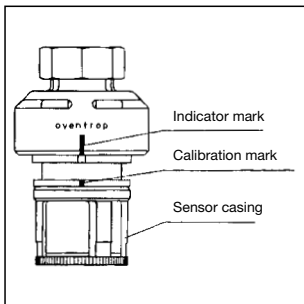

2

Photo 2: After having removed the handgrip: Turn the sensor casing to the left until the calibration mark (bore or white stroke) is in line with the indicator mark.

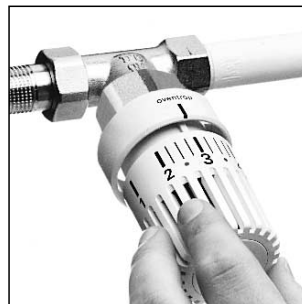

6

Photo 6: Replace the handgrip so that figure "3" is in line with the indicator mark.



3

Photo 3: On the inner side of the handgrip you will find two clips in the "parking" position. They should be removed by sliding to the outside. (When not in use, the clips may of course be put back in the "parking" position.)



7

Photo 7: Push down handgrip with hand to secure. The control range of the thermostat is now limited and you can only set values between figure "2" and "4" (approx. 16 °C – 24 °C).

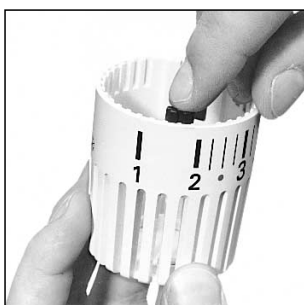

4

Photo 4: To limit the minimum control range, e.g. at figure "2" (equals approx. 16 °C), one clip should be fitted into the groove immediately **before** figure "2" as illustrated. (The groove directly opposite figure "2" thus remains free.)

Blocking the temperature setting

To prevent unauthorised tampering, any temperature setting of the thermostat can be locked. Example: Locking temperature setting to figure "2". (equals approx. 16 °C, e.g. for hallways and bedrooms). To do so, first remove handgrip as described beside photo 1. Then turn sensor casing until the calibration mark (bore or white stroke) is in line with the indicator mark (as described beside photo 2).



8

Photo 8: Replace handgrip **loosely** so that figure "3" is in line with the indicator mark.



9

Photo 9: Turn handgrip to figure "2" while pressing it gently. Remove handgrip. (The calibration on the sensor casing is now turned to the right.)

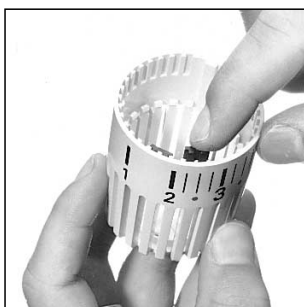

10

Photo 10: The two clips on the inner side of the handgrip are to be removed as described beside photo 3 and to be placed in the grooves immediately before and after figure "2". (The groove directly opposite figure "2" thus remains free.)



11

Photo 11: The handgrip now is to be replaced so that figure "2" is in line with the indicator mark. The setting is now locked in position "2" (approx. 16 °C). Push down handgrip with hand firmly to secure.

Recalibration

The thermostat is adjusted at works to 20 °C = figure "3". Should this adjustment be altered, you can recalibrate as follows:



12

Photo 12: To remove the handgrip either the tool (item no. 198 91 00) or a suitable pin, e.g. the push button of a pen, should be inserted in the hole on the lower side of the thermostat. By turning the handgrip to the right into shut-off position, it is easily removed.



13

Photo 13: Remove handgrip. Turn sensor casing to the right until it is fully screwed into the body of the thermostat, then turn to the left again until the calibration mark (bore or white stroke) is in line with the indicator mark.

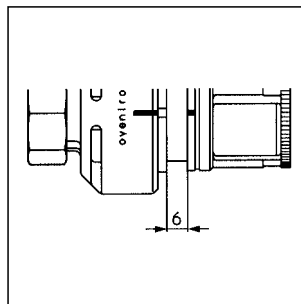

14

Photo 14: If the sensor casing is for some reason unscrewed completely from the body of the thermostat, please note that when replacing the element, because of the double start thread, the correct start thread is used. After recalibration, the distance between the body and the sensor casing has to be approx. 6 mm.

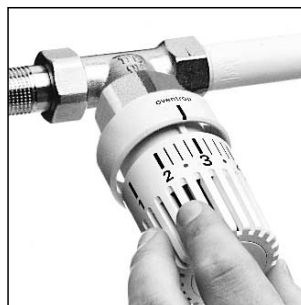

15

Photo 15: Replace handgrip so that figure "3" on the handgrip is in line with the indicator mark. Push down firmly with hand to secure.

Cancellation of limitation or locking

If the control range is limited or locked with the clips, the handgrip cannot be removed as shown on photo 1 or 12. In this case the following method should be used:

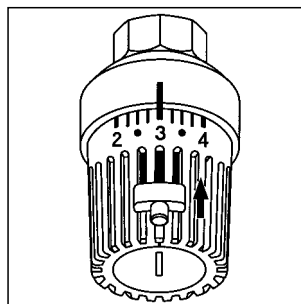

16

Illustr. 16: Locked temperature setting: Insert tool (item no. 198 91 00) on top of the handgrip so that one bridge is in the groove immediately before and one bridge in the groove immediately after the indicator mark. Push tool in direction of arrow to loosen the clips. Remove tool.

Limited control range: Turn the handgrip to minimum or maximum value of set control range. Place tool on top of the handgrip so that one bridge

is in the groove immediately before and one bridge in the groove immediately after the indicator mark. Push tool in the direction of arrow to loosen clips. Remove tool.

The handgrip can now be removed as shown on photo 1. Remove clips and reposition.

Replacement of the gland nut

Remove thermostat from the valve. Unscrew the gland nut with a 14 mm key. Water will not escape as the valve is provided with an additional seal. Screw on new gland nut (item no. 101 75 01) and tighten with key. Replace the thermostat.

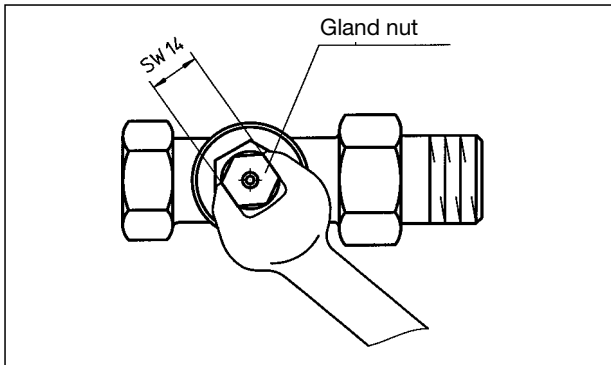

Note:

Not for "Series AV6, ADV6, RFV6".

Check list for faults

The desired room temperature is not reached or maintained

1. The flow temperature is set too low.
2. The circulation pump is not switched on.
3. The circulation pump or the flow temperature is controlled by a separate electric room thermostat.
4. The pump output is set too low.
5. The flow direction of the pump is reversed.
6. The heating pipe is throttled back or shut off.
7. With gravity fed heating systems, a circulation pump must be installed subsequently if necessary. Gravity systems are very sensitive to the presence of air in the system.
8. The radiator is covered by curtains, panelling etc. Use a thermostat with remote sensor.
9. Temperature at the thermostat differs widely from the ambient temperature due to poor siting. Use a thermostat with remote sensor.
10. The remote sensor is badly sited. The best height is about 1 m above the floor level.
11. The radiator selected is too small for the size of the room.
12. If the required temperature is only reached at a higher setting of the thermostat, recalibrate the thermostat (if desired).

The thermostatic radiator valve does not function

13. The thermostat is not screwed tightly onto the valve.
14. The capillary of the remote sensor or the remote control was kinked or flattened. Use a new thermostat and install carefully.
15. If a strainer is used, has it become blocked? Remove valve, flush pipe thoroughly, clean strainer and re-install.
16. Air is reducing circulation in the radiator. Vent the radiator.
17. Air is interfering with circulation in the heating system. Fit an automatic airvent in a suitable position.
18. The valve seat was distorted, e.g. as a result of improper assembly in vice. Fit a new valve.
19. The thermostat was readjusted due to unauthorised tampering. Recalibrate thermostat (see page 3).

The valve cannot be shut off

20. In most cases this is due to dirt particles on the valve disc, e.g. welding beads or rust particles. These particles can often be removed by repeatedly working the valve stem. To do this, the thermostat must be removed first.

The valve insert must be replaced if the valve disc was damaged. The valve insert can be replaced without draining the system with the help of the "Demo-Bloc" tool specially developed for this purpose. If this is not successful, the valve insert must be removed after having drained the system and the residue has to be removed from the valve or the valve has to be replaced.

21. The frost protection responds. The crystal symbol * corresponds to a room temperature of about 7 °C. The valve will therefore open as soon as the temperature drops below this level, e.g. when ventilating the room.
22. The thermostat is defective and must be replaced. First test whether this is due to dirt or unauthorised tampering of the calibration. Screw on a new thermostat and send the old one back to the supplier for replacement. If still under guarantee, it will be repaired or replaced free of charge.

The valve leaks

23. The gland nut is loose. Tighten it.
24. The O-ring seal of the gland nut is damaged. Replace the gland nut. The system does not have to be drained to do this (see above).
25. The valve insert is loose. Tighten. If necessary, use a new insert (compare point 20).

The valve rattles

26. Supply and return pipe are reversed.

Flow noises occur

27. Can the pump head (differential pressure) be reduced?

Please contact the manufacturer in case of further questions.

Subject to technical modification without notice.

Product range 1
Edition 2005

Printed on paper free from
chlorine bleaching.

OVENTROP UK LTD.
Unit 1 – The Loddon Centre
Wade Road
Basingstoke, Hampshire RG24 8FL
Telephone (01256) 330441
Telefax (Sales) (01256) 330525
Telefax (General) (01256) 470970
E-Mail sales@oventrop.co.uk

F. W. OVENTROP GmbH & Co. KG
Paul-Oventrop-Straße 1
D-59939 Olsberg
Telephone (02962) 82-0
Telefax (02962) 82-450
Internet www.oventrop.de
E-Mail mail@oventrop.de